



F O1

Sedie · collettività

Guest and stacking chairs · Chaises collectivité
Objektstühle · Sillas para colectividad



F O2

Poltrone operative

Task chairs · Sièges operatifs
Drehstühle · Sillas operativas



F O3

Poltrone direzionali

Executive and managerial swivel chairs · Fauteuils direction
Chefsessel · Sillones direccionales



F O4

Riunioni · attesa · travi · tavoli

Meeting · lounge seating, benches, tables · Sièges attente-réunion, poutres, tables
Polstergruppen, bänke, tische · Reunión, espera, bancadas, mesas

F

Finiture · rivestimenti

Textiles and Leathers · Revêtements
Bezüge · Tejidos

ERGONOMY

Kastel progetta e produce sedute che rispettano le esigenze ed i limiti dell'uomo, garantendo l'integrità fisica e psicologica che ne potenzia le capacità operative. L'obiettivo è quello di accrescere l'efficienza dell'utente e di contribuire al suo benessere psicofisico.

Kastel designs and manufactures seating that meet the necessities and limitations of people, ensuring the physical and psychological integrity that enhances the operational capabilities. The goal is to increase user efficiency and to contribute to his psychophysical well-being.





_11



_13

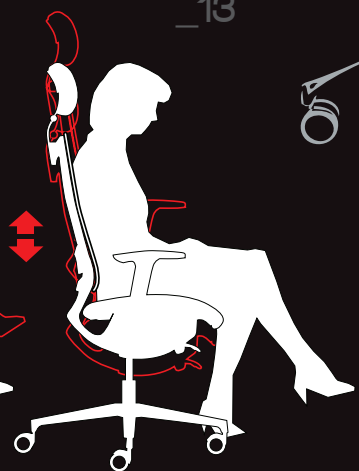

_15

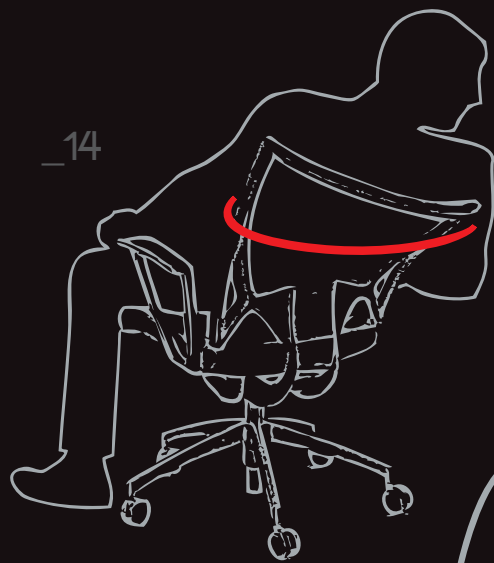

_14



_16

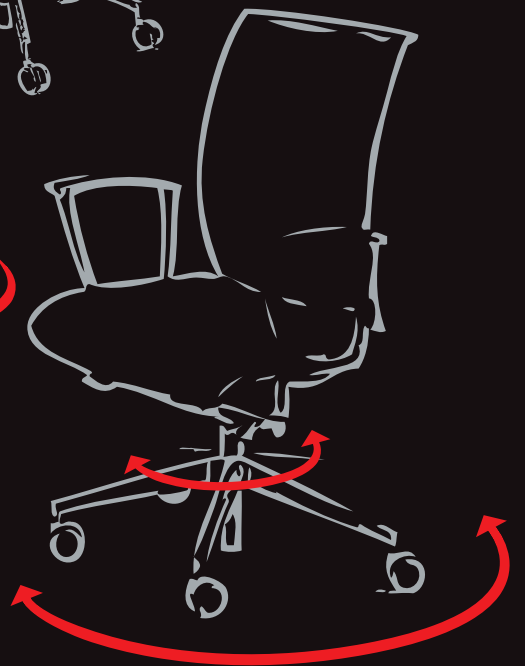

_17

F01 SEDIE · COLLETTIVITÀ

Guest and stacking chairs · Chaises collectivité
Objektstühle · Sillas para colectividad



F02 POLTRONE OPERATIVE

Task chairs · Sièges opératifs
Drehstühle · Sillas operativas



F03 POLTRONE DIREZIONALI

Executive and managerial swivel chairs · Fauteuils direction
Chefsessel · Sillones direccionales



F04 RIUNIONE · ATTESA · TRAVI · TAVOLI

Meeting - lounge seating, benches, tables
Sièges attente-réunion, poures, tables
Polstergruppen, banke, tische
Reunión, espera, bancadas, mesas



F RIVESTIMENTI

Textiles and Leathers · Revêtements
Bezüge · Tejidos

T76 - T81

Kat



T19

Kat (padded)



T19

Klou



T18

Kensho (stool)



T18

Kimbox (stool)



T17

Kalea



T20

Kicca



T21

Kat



T19

Konfort



T24

Kubix



T25

Kolor



T27

Konvert



T31

Konca (mesh)



T32

Korium (mesh)



T33

Korium plus



T33

Kamelia



T40

Klassik



T43

Kya



T42

Kapitol



T42

Klaro



T43

Base
Mechanism



T6-T7

Krokus



T50

Kimera (waiting)



T54

Kimera
(waiting rhomboidal)



T54

Kosa



T54

Koccola



T51

Koccola plus



T51

Koccola top



T52

Kroff



T53

Kensho (pouf)



T52

Kubox



T53

Komodo



T59

Klasse



T61

Korall



T59

Kristall



T60

Kalypso



T61

Klub



T58

Korner



T67

Kargo



T67

Kadenza (tip up)



T68

Konvegno (tip up)



T69

Kensho (tables)



T70

Kapio



T71

Kaleox



T72-T73

**BASE**

(Le varianti basi girevoli o telai fissi vanno sempre indicate nell'ordine)
(All the codes for swivel bases or fixed frame must be indicated in the order)

**APN** (Ø 670)

Base in acciaio con cuffia in polipropilene
Steel base with polypropylene guard
Piètement en acier recouvert de polypropylène
Fusskreuz- Stahlgestell mit Abdeckung aus Polypropylen
Base en acero con embellecedor en polipropileno

**AL7** (Ø 675)

Base in alluminio pressofuso lucido
Polished die-cast aluminium base
Piètement en fonte d'aluminium polie
Fusskreuz aus Pressguss-Aluminium, glänzend
Base en aluminio pulido



040080*

RUOTE - CASTORS

con/with base
APN -AL7
Ruota gommata con freno ø 50
Soft braked castor ø 50
Roulette autofreinée pour sol dur ø 50
Weiche selbstbremsende Doppelrolle ø 50
Rueda autofrenada ø 50

*per pavimenti in pietra dura,
legno e piastrelle EN 1335-2

**APS** (Ø 660)

Base in nylon nero
Black nylon base
Piètement en nylon noir
Fusskreuz aus schwarzem Nylon
Base en nylon negro

**AL6** (Ø 654)

Base in alluminio pressofuso lucido
Polished die-cast aluminium base
Piètement en fonte d'aluminium polie
Fusskreuz aus Pressguss-Aluminium, glänzend
Base en aluminio pulido

**APG** (Ø 675)

Base in nylon grigio
Grey nylon base
Piètement en nylon gris
Fusskreuz aus grauem Nylon
Base en nylon gris

**APW** (Ø 675)

Base in nylon bianco
White nylon base
Piètement en nylon blanc
Fusskreuz aus weissem Nylon
Base en nylon blanco

040108* (Set n. 5)



con/with base
APS-APG-APW-AL6-AL8-AL9
Ruota gommata con freno ø 65
Soft braked castor ø 65
Roulette autofreinée pour sol dur ø 65
Weiche selbstbremsende Doppelrolle ø 65
Rueda autofrenada ø 65

*per pavimenti in pietra dura,
legno e piastrelle EN 1335-2

**AL8** (Ø 640)

Base in alluminio pressofuso, lucido sulla parte superiore
Die-cast aluminium base, polished on the upper part
Piètement en fonte d'aluminium, polie sur la partie supérieure
Fusskreuz aus Aluminiumdruckguss, poliert im Oberteil
Base en aluminio, pulido en la parte superior

**AL9** (Ø 640)

Base in alluminio pressofuso verniciato
Die-cast base aluminium painted
Piètement en fonte d'aluminium verni
Fußkreuz aus Pressguss-Aluminium, lackiert
Base en aluminio pintado

**AL4** (Ø 730) (Non usare su versioni oscillante - Don't use it on tilt versions)

Base 4 razze in alluminio pressofuso lucido solo con piedini
4-stars polished die-cast aluminium base only with feet
Piètement 4-branches en fonte d'aluminium polie avec patins
4-Fusskreuz aus Pressguss-Aluminium, glänzend mit Gleitern
4-radios base en aluminio pulido con deslizadores

**AL5** (Ø 654)

Base in alluminio pressofuso lucido (c/ruote e gas cromati)
Polished die-cast aluminium base (w/chromed castors and gaslift)
Piètement en fonte d'aluminium polie (avec roulettes et gaz chromés)
Fusskreuz aus Pressguss-Aluminium, glänzend (mit verchromten rollen+Gasfeder)
Base en aluminio pulido (con ruedas y gas cromados)

040109* (Set n. 5)

**RUOTE - CASTORS**

con/with base
AL5
Ruota gommata con freno ø 65
Soft braked castor ø 65
Roulette autofreinée pour sol dur ø 65
Weiche selbstbremsende Doppelrolle ø 65
Rueda autofrenada ø 65

*per pavimenti in pietra dura,
legno e piastrelle EN 1335-2

Synchron (vari modelli - different models)

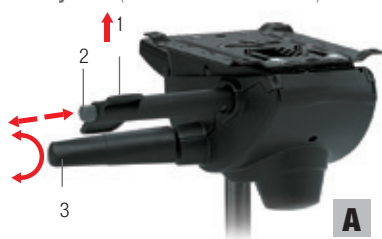

Synchron + Traslatore + Varia (Variatore angolo sedile-schienale) (vari modelli)
Synchron + Slide System + Varia (Seat-back angle adjustment) (different models)

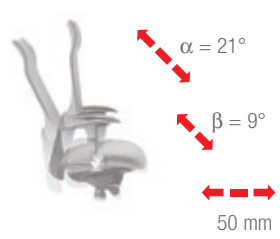

Modelli/Models: Kuper/Konica



Modelli/Models: Konica

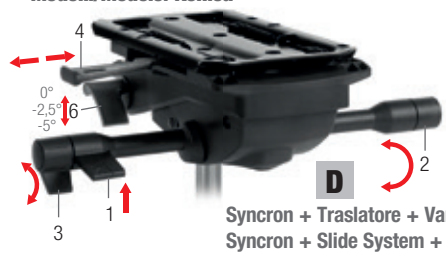

3-Regolazione rapida di intensità di carica in 10 diverse posizioni con 1/4 di giro della leva
Fast tension adjustment in 10 different positions by 1/4 of turn lever

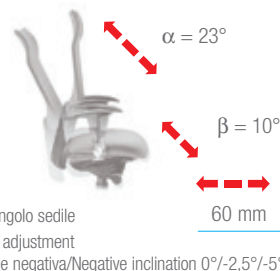

Synchron + Traslatore + Varia
Synchron + Slide System + Varia
6-Variatore angolo sedile
Seat angle adjustment
 (inclinazione negativa/Negative inclination 0°/-2,5°/-5°)

Modelli/Models: Kubika/Kamelia



Modelli/Models: Kubika/Kamelia

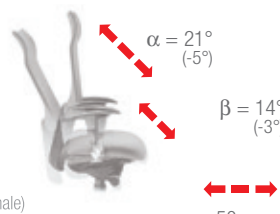
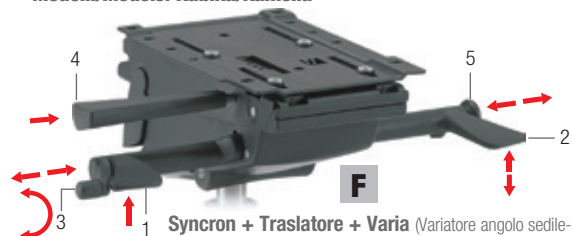

Synchron + Traslatore + Varia (Variatore angolo sedile-schienale)
Synchron + Slide System + Varia (Seat-back angle adjustment)
 (inclinazione negativa/Negative inclination: -3°sedile/seat -5° schienale/back)

Modelli/Models: Kuper (easy mesh)/Konica

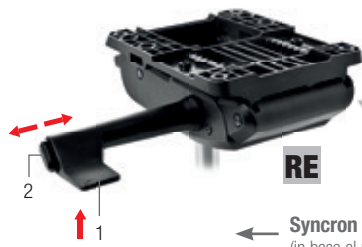

Modelli/Models: Kuper (easy mesh)

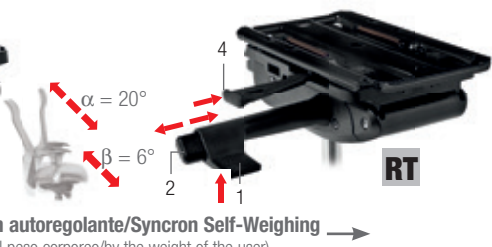

Modelli/Models: Kroma-Konfort-Kubix

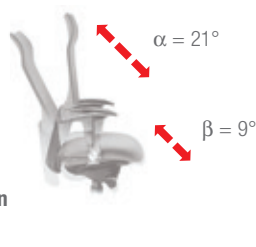

Synchron autoregolante/Synchron Self-Weighing
 (in base al peso corporeo/by the weight of the user)

Modelli/Models: Kruna/Kimera/King Kompasso/Kya/Klaro Kapitoll/Klassic



Modelli/Models: Kimera/King/Kompasso Klassic/Klaro



Modelli/Models: Kruna

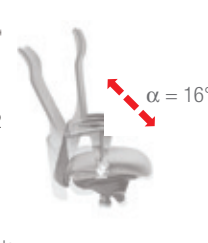

Oscillante-''Knee tilt''
 (Con punto di rotazione avanzato
 With advanced point of tilting)

Oscillante-''Knee tilt''
 (Con punto di rotazione avanzato
 With advanced point of tilting)

- 1 - Leva di alzo seduta
 - Seat height adjustment
 - Réglage hauteur assise
 - Sitzhöhenverstellung
 - palanca de regulación altura asiento

- 2 - Blocco e sblocco oscillazione
 - Tilt movement control
 - Blocage et deblocage de la bascule
 - Hebel für die Regulierung der Neigungsbewegung
 - Para bloqueo y liberación basculante

- 3 - Regolatore intensità di carica
 - Tension adjustment
 - Réglage tension
 - Einstellmöglichkeit der Federkraft
 - regulador tensión

- 4 - Leva regolazione profondità seduta
 - Seat depth adjustment
 - Réglage en profondeur de l'assise
 - Hebel für die Sitztiefenverstellung
 - palanca de regulación profundidad asiento

- 5 - Varia
 - Variatore d'assetto, funzione che limita l'escursione in avanti dello schienale
 - Attitude variator, limiting the movement of the backrest forward
 - Variateur d'assiette pour limitation de course en avant du dossier
 - Lageregler: Vorrichtung zur Begrenzung des Vorschubs der Rückenlehne nach vorne
 - Control movimiento del respaldo.

Tutti i meccanismi sono dotati di blocco automatico (5 posizioni) e sistema antishock / All mechanisms stop automatically (5 positions) and have antishock system.



Sedie · collettività

Guest and stacking chairs

Chaises collectivité

Objektstühle

Sillas para colectividad





Sedia impilabile multiuso

- scocca in polipropilene mono o bicolore
- scocca in polipropilene mono o bicolore con sedile imbottito
- scocca in polipropilene, sedile e schienale imbottiti, mono o bicolore

Multipurpose chair with

- one colour or bicolor polypropylene shell
- one or two colours polypropylene shell with padded seat
- one or two colours polypropylene shell with padded seat and backrest

Chaise à différent usages

- coque en polypropylène monocolore ou deux couleurs
- coque en polypropylène, monocolore ou à deux couleurs avec assise rembourrée
- coque en polypropylène, monocolore ou à deux couleurs avec assise et dossier rembourrée

Mehrzweckstuhl

- Schale aus Polypropylen einfarbig oder zweifarbig
- Schale aus Polypropylen ein- oder zweifarbig mit Sitz gepolstert
- Schale aus Polypropylen ein- oder zweifarbig mit Sitz-Rücken gepolstert



Polipropilene monocolore

One colour polypropylene

Retroschienale lucido

Glossy backshell



Polipropilene bicolore

Two colours polypropylene

Retroschienale lucido

Glossy backshell

* Impilabile (per le versioni imbottite aggiungere il carter sottosedile)
Stackable (for upholstered versions add underseat shell)



Monocolore/bicolore

One or two colours

Sedile imbottito

Padded seat



AV
Vern. col. alluminio
Alu painted frame



Sedile-schienale imbottiti monocolore o bicolore

Padded seat-backrest one or two colours



AB
Vern. col. bianco
White painted frame



Carter per impilabilità sedile imbottito

Under seat shell to stack the chairs for padded seat version



AN
Vern. col. nero
Black painted frame



Carter per agganciabilità sedile

Under seat shell with linking device



ACC
Cromato
Chromed frame

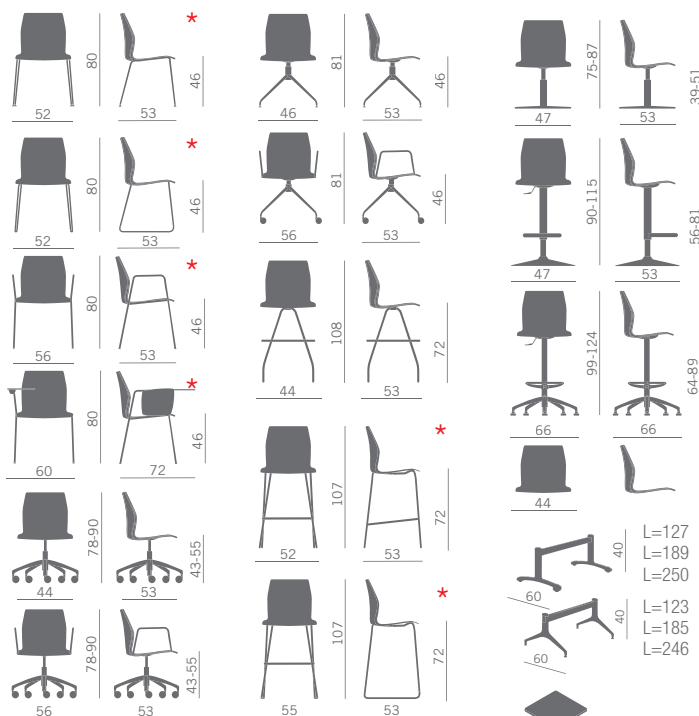

Monocolore
One colour



C Crema (bianco)
Cream (White)

T Tortora
Dove-colour

V Verde
Green

R Rosso
Red

A Arancio
Orange

B Blu
Blue

G Grigio
Grey

N Nero
Black

Polipropilene bicolore
Two colours polypropylene

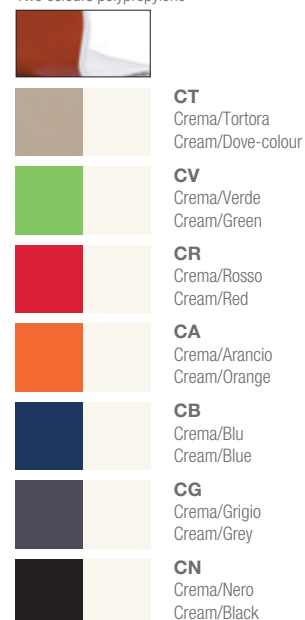

CT Crema/Tortora
Cream/Dove-colour

CV Crema/Verde
Cream/Green

CR Crema/Rosso
Cream/Red

CA Crema/Arancio
Cream/Orange

CB Crema/Blu
Cream/Blue

CG Crema/Grigio
Cream/Grey

CN Crema/Nero
Cream/Black





KICCA Modello registrato - Registered model

Sedia impilabile multiuso con:

- 8 versioni di telaio
- scocca in polipropilene in 8 colori
- scocca in polipropilene con sedile imbottito
- scocca in polipropilene con sedile e schienale imbottito

Multipurpose stackable chair, with:

- 8 frame versions
- polypropylene shell available in 8 colours
- polypropylene shell with padded seat
- polypropylene shell with padded seat and back.

Chaise empilable à différents usages avec:

- 8 versions de piétement
- coque en polypropylène disponible en 8 couleurs
- coque en polypropylène avec assise rembourrée
- coque en polypropylène avec assise et dossier rembourré

Stapelbarer Mehrzweckstuhl mit:

- 8 Gestellausführungen
- Schale aus Polypropylen lieferbar in 8 Farben
- Polstersitz
- Sitz und Rücken gepolstert

Silla multiuso apilable con:

- 8 versiones de estructura
- Carcasa en polipropileno disponible en 8 colores
- Carcasa en polipropileno con asiento tapizado
- Carcasa en polipropileno con asiento y respaldo tapizados.



* Impilabile (per le versioni imbottite aggiungere il carter sottosedile)
Stackable (for upholstered versions add underseat shell)

Polipropilene/Polypropylene



C/sedile imbottito
W/padded seat



AV
Vern. col. alluminio
Alu painted frame

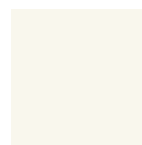

C
Crema (bianco)
Cream (White)
Crème (blanc)
Creme (Weiss)
Crema (blanco)



A
Arancio
Orange
Orange
Orange
Naranja



C/sedile-schienale
imbottito
W/padded seat-back



AB
Vern. col. bianco
White painted frame



T
Tortora
Dove-colour
Tourterelle
Taube
Arena



B
Blu
Blue
Bleu
Blau
Azul



Carter per
impilabilità sedile
imbottito
Under seat shell to
stack the chairs for
padded seat version



AN
Vern. col. nero
Black painted frame



V
Verde
Green
Vert
Grün
Verde



G
Grigio
Grey
Gris
Grau
Gris



Carter per
agganciabilità sedile
Under seat shell
with linking device



ACC
Cromato
Chromed frame



R
Rosso
Red
Rouge
Rot
Rojo



N
Nero
Black
Noir
Schwarz
Negro



Gambe legno - Wood legs



KRIZIA Modello registrato - Registered model

Sedia in policarbonato su telai fissi impilabile o girevole

- Bianco - rosso - moka - nero - trasparente
- Sedile imbottito
- Sedile + schienale imbottiti

Polycarbonate stackable chair with either fixed frames or swivel bases.

- White - red - mocca - black - transparent
- Padded seat
- Padded seat and back

Chaise empilable en polycarbonate avec piétements fixes ou pivotants

- Blanc - rouge - moka - noir - transparent
- Assise rembourrée
- Assise et dossier rembourré

Stapelbarer Stuhl aus Polycarbonat mit 4-Fuß-Gestellen oder drehebbar

- Weiß - rot - mocca - schwarz - transparent
- Polstersitz
- Sitz und Rücken gepolstert

Silla en policarbonato con estructuras fijas apilables o giratorias.

- Blanco - rojo - moka - negro - transparente
- Asiento tapizado
- Asiento + respaldo tapizados

Gambe legno - Wood legs
(no stackable)

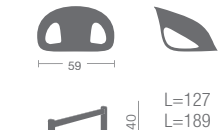
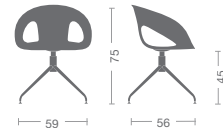
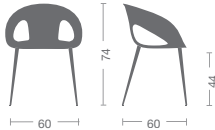

Gambe acciaio - Steel legs
(stackable)

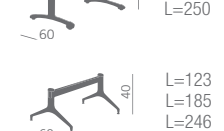
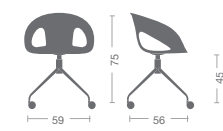
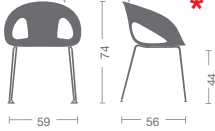

Polycarbonato - Polycarbonate



B
Bianco
White
Blanc
Weiss
Blanco



Sedile imbottito
Padded seat



- *Impilabile
(no versioni imbottite)
- *Stackable
(no padded versions)



R
Rosso
Red
Rouge
Rot
Rojo



Sedile/schienale imbottiti
Padded seat/back



AV
Vern. col. alluminio
Alu painted frame



M
Moka



4 gambe faggio verniciato
4 legs painted beechwood



AB
Vern. col. bianco
White painted frame



N
Nero
Black
Noir
Schwarz
Negro



4 gambe faggio verniciato bianco
4 legs white painted beechwood



ACC
Cromato
Chromed frame



T
Trasparente
Transparent
Transparent
Transparent
Transparente



A richiesta
Omologazione al fuoco Classe 11M
(versioni imbottite)

KYOS-KYOS MESH



Sedia impilabile multiuso

- telai a 4 gambe o slitta, con o senza braccioli
- versioni con scocche in polipropilene bianco, grigio, nero
- versioni con sedile imbottito
- versioni con sedile e schienale imbottiti

Multipurpose stack chair

- 4-legs frames or cantilever bases, with or without arms
- versions with white, grey or black polypropylene shells
- versions with padded seat
- versions with padded seat and back

Chaise multi-usages, empilable

- piétements à 4-pieds ou luge, avec ou sans accoudoirs
- versions avec coques en polypropylène blanc, gris ou noir
- versions avec assise garnie
- versions avec assise et dossier garnis

Stapelbarer Mehrzweckstuhl

- 4-Fuss-Gestell oder Freischwinger, mit oder ohne Armlehnen
- Schale aus Polypropylen in den Farben weiß, grau, schwarz
- Polstersitz
- Sitz und Rücken gepolstert

Silla apilable multiuso

- estructuras a 4 patas o patín, con o sin brazos
- versiones con carcasas en polipropileno blanco, gris o negro
- versiones con asiento tapizado
- versiones con asiento y respaldo tapizados

Polipropilene Polypropylene



Bianco
White



Grigio
Grey



Nero
Black



Sedile imbottito
Padded seat



Sedile/schienale imbottiti
Padded seat/back



Kyos (mesh)
Schienale con rete D222
Mesh backrest D222

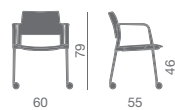
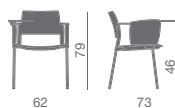
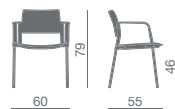
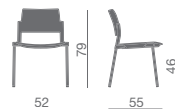

Impilabile
(4 gambe e slitta)
Stackable
(4-legs and sled)



Tavoletta scrittoio nera
antipanic
Antipanic black writing
tablet



Tavoletta scrittoio
antipanic grigia
Antipanic grey writing
tablet



Coppia aggancio
Linking device
Ingombro L=55
Senza braccioli L=62
Con braccioli
Overall dimensions
No arms L=55
With arms L=62

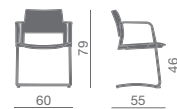
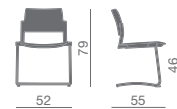

AV
Verniciato alluminio
Alu painted



AN
Verniciato nero
Black painted



AB
Verniciato bianco
White painted



ACC
Cromato
Chromed



Normativa europea EN 15373
(versione 4 gambe)



A richiesta
Omologazione al fuoco
Classe 1IM versioni imbottite
e polipropilene nero



Sedia impilabile su telaio 4-gambe cromato, basi girevoli e versioni panca con:

- Scocca in rovere naturale o in faggio verniciato bianco
- Scocca con sedile imbottito
- Scocca con sedile e schienale imbottiti

Stack chair with 4-legs chromed frame, swivel bases and bench version with:

- Natural oak wood shell or white painted beechwood
- Shell with padded seat
- Shell with padded seat and back

Chaise disponible sur châssis chromé 4-pieds empilable, ou bases pivotantes et version sur poutre avec:

- Coque en multiplis de chêne naturel ou en hêtre verni blanc
- Coque avec assise garnie
- Coque avec assise et dossier garnis

Stapelstuhl mit Gestellen verchromt, drehbar oder auf Traverse, erhältlich mit:

- Schale aus Eichenholz natur lackiert oder aus Buchenholz weiss lackiert
- Schale mit Sitz gepolstert
- Schale mit Sitz+Rücken gepolstert

Silla apilable con estructura cromada, bases giratorias y versión para bancada con:

- Carcasa en roble natural o haya pintada blanca
- Carcasa con asiento tapizado
- Carcasa con asiento y respaldo tapizados



Faggio verniciato bianco
White painted beechwood

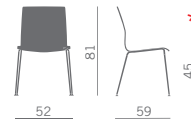

Rovere naturale
Natural oak wood

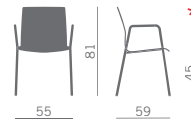

Sedile imbottito
Padded seat

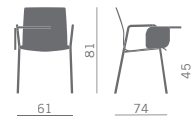

Sedile/schienale imbottiti
Padded seat/back

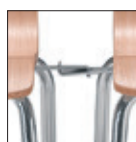
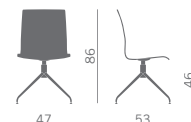

Coppia agganci
Linking devices

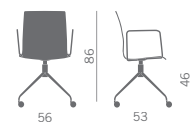

* Impilabile
Stackable
Empilable
Stapelbar
Apilable

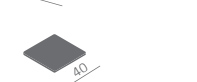
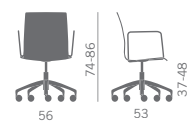
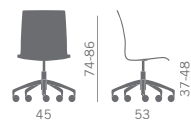
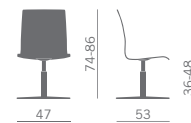

Normativa europea EN 13761
(versione 4 gambe)



A richiesta
Omologazione al fuoco Classe 1IM
(con sedile o sedile/schiena imbottiti)

O1 KRIMM



Sedia impilabile multiuso con braccioli nelle versioni:
 - sedile imbottito, con schienale in polipropilene nero
 - sedile e schienale imbottito.

Stack polyfunctional chair with arms available in the following versions:
 - with upholstered seat and backrest in black polypropylene
 - padded seat-back.

Chaise empilable à différents usages
 avec accoudoirs disponible dans les versions suivantes:
 - avec assise rembourrée et tapissée et dossier en polypropylène noir
 - avec assise et dossier rembourrés.

Stapelbarer Mehrzweckstuhl mit Armlehnen erhältlich in den folgenden Ausführungen:
 - mit gepolstertem Sitz und Rückenlehne aus schwarzem Polypropylen
 - mit Sitz und Rückenlehne gepolstert.

Silla apilable multiuso con brazos en las versiones:
 - Asiento embutido y tapizado con respaldo en polipropileno negro
 - Asiento y respaldo embutidos y tapizados.

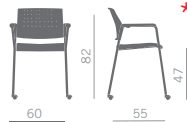
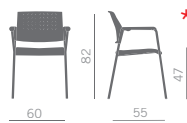
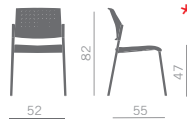

* Impilabile
 Stackable
 Empilable
 Stapelbar
 Apilable



Sedile imbottito
 Padded seat



Sedile-schienale imbottiti
 Padded seat-backrest



A richiesta
 Omologazione al fuoco Classe 1IM

O1 KALLA



Sedia e poltroncina multiuso nelle versioni:
 - 4 gambe in alluminio verniciato

Multifunctional chair available in the following versions:
 - 4-legs painted aluminium frame

Chaise polyvalente disponible dans les versions suivantes:
 - 4-pieds époxy aluminium

Mehrzweckstuhl lieferbar in folgenden Ausführungen:
 - mit Vierfuss Gestell aus lackiertem Aluminium

Silla multiuso en las versiones:
 - 4 patas en aluminio pintado

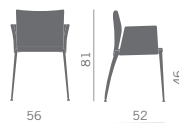
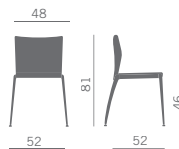

Particolare schienale
 Backrest detail



Coppia agganci
 Linking devices

A richiesta
 Omologazione al fuoco Classe 1IM

O1 KLIC



Sedie multiuso su telaio 4-gambe impilabile o su telaio a slitta in acciaio verniciato alluminio o cromato, con sedile imbottito e schienale in polipropilene nero, grigio oppure imbottito.

Multifunctional chairs with 4-legs stacking frame or sled frame in painted aluminium or chromed steel, available with padded seat and with black or grey polypropylene backrest or completely upholstered.

Chaises multi-usages avec piétement à 4-pieds empilable ou luge en acier époxy aluminium ou chromé, l'assise est rembourrée et le dossier est en polypropylène noir ou gris ou rembourré.

Mehrzweckstühle mit stapelbarem Vierfußgestell oder Freischwingersgestell aus alusilber lackiertem oder verchromtem Stahl, mit Polstersitz und Rückenlehne wahlweise gepolstert oder aus schwarzem bzw. grauem Polypropylen

Sillas multiuso con estructura 4 patas apilable o con base patín en acero pintado aluminio o cromado, con asiento tapizado y respaldo en polipropileno negro, gris o tapizado.



Schienale nero
Black
backrest



Schienale grigio
Grey
backrest



Schienale imbottito
Padded
backrest



Telaio verniciato
alluminio
Aluminium
painted frame



Telaio cromato
Chormed frame

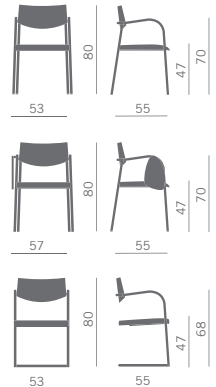

A richiesta
Omologazione al fuoco
Classe 1IM



O1 KELLY



Sedia su telaio o slitta verniciato col. alluminio o cromato
- Schienale in rete o rivestito
- Sedile imbottito

Chair with painted aluminium or chromed sled base
- Backrest in mesh or upholstered
- Padded seat

Chaise avec piétement luge époxy aluminium ou chromé
- Dossier en résille ou revêtu
- Assise garnie

Freischwingerstuhl, aluminium lackiert oder verchromt
- Rücken mit Netzbespannung oder gepolstert
- Sitz gepolstert

Silla con base o patín pintada color aluminio o cromada
- Respaldo en malla o tapizado
- Asiento tapizado

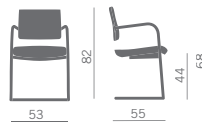

Schienale imbottito
Padded
backrest



Schienale rete
Mesh
backrest



Telaio verniciato
alluminio
Aluminium
painted frame



Telaio cromato
Chromed frame

Rete poliestere vari colori - Various colors of polyester mesh



D218 D219 D220 D221 D222

O1 KAMPUS "CUOIETTO"



Sedie multiuso su telaio 4-gambe o telaio a slitta in acciaio verniciato alluminio o cromato.
Cuoietto nero - bordeaux.

Multifunctional chairs with 4-legs frame or sled frame in aluminium painted or chromed steel.
Black burgundy "cuoietto".

Chaises multi-usages avec piétement à 4-pieds ou luge en acier époxy aluminium ou chromé.
Cuir sellier noir - bordeaux.

Mehrzweckstühle mit Vierfußgestell oder Freischwingersgestell aus alusilber lackiertem oder verchromtem Stahl.
Schwarz - bordeauxrot.

Sillas multiuso con estructura 4 patas o con base patin en acero pintado aluminio o cromado.
Cuero negro - granate.



KAMPUS
"Cuoietto"
Nero/Black

"Cuoietto"
Bordeaux

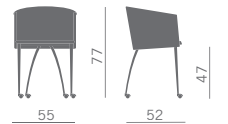
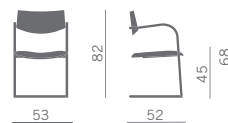
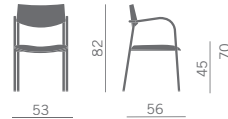

O1 KIMBOX (SGABELLO-STOOL)



Sgabello in cuoietto nero o bianco su telai fissi o girevoli

Stool in black or white saddled leather, with fixed or swivel frames

Tabouret en cuir sellier noir ou blanc, sur piétements fixes ou pivotants

Hocker in Kernleder schwarz oder weiß, Gestelle fest oder drehbar

Taburete en cuero blanco o negro, con estructuras fijas o giratorias.



Base per fissaggio a pavimento
Base to be fixed on the floor



"Cuoietto"
nero/black



"Cuoietto"
bianco/white

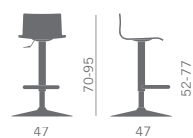
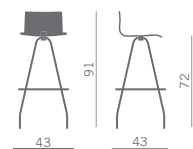
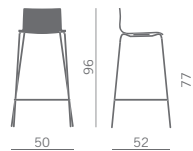

Base piana bianca
White flat base
d. 48



Base piana cromata
Chromed flat base
d. 48

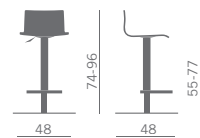

F/O1 KENSHO (SGABELLO-STOOL)



Sgabello imbottito a forma triangolare arrotondata.
Monocolore o bicolore.

Round edged triangle padded stool. One color or two colors upholstery.

Tabourets garnis en forme de triangle arrondi.
Revêtement unicolore ou deux couleurs.

Gepolsterter Hocker dreieckig mit gebogenen Kanten.
Einfarbig oder zweifarbig.

Taburete de forma triangular redondeada, tapizado.
Mono-color o bi-color.

Basi - Bases



Bianco
White
d. 41



Tortora
Dove-colour
d. 41



Monocolore
One colour

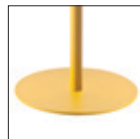

Giallo
Yellow
d. 41



Lava
Lava
d. 41



Bicolore
Two colours

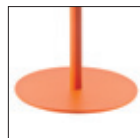

Arancio
Orange
d. 41



Cromato
Chromed
d. 41



Base piana bianca
White flat base
d. 48



Base piana cromata
Chromed flat base
d. 48



A richiesta
Omologazione al fuoco Classe 11M

F/O1 KLOU



Sgabello con sedile in poliuretano integrale morbido su telai fissi o girevoli.

Stool with soft integral polyurethane seat on fixed or swivel frames.

Tabouret avec assise en polyuréthane souple montée sur châssis fixe ou pivotant.

Hocker mit Sitz aus weichem Polyurethanschaum mit Gestell drehbar oder fest.

Taburete con asiento en poliuretano integral blando, con bases fijas o giratorias.

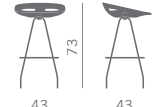
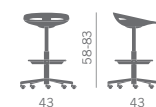
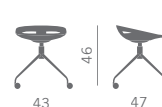
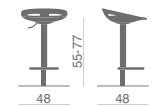

Base per fissaggio
a pavimento

Base to be fixed
on the floor



Base piana bianca
White flat base
d. 48



Base piana cromata
Chromed flat base
d. 48



Antracite
Anthracite
Anthrazit
Gris oscuro



Grigio chiaro
Light grey
Gris claire
Hellgrau
Gris claro



Arancio
Orange
Orange
Orange
Naranja



Sgabelli

- legno verniciato
- poliuretano espanso integrale nero
- varie basi girevoli

Stool

- varnished wood
- black integral expanded polyurethane.
- various swivel bases.

Tabouret

- en bois verni
- en polyuréthane expansé intégral noir
- divers piétements pivotants

Hocker

- Holz lackiert
- Schwarzes Polyurethanschaum
- Verschiedene Drehgestelle

Taburetes

- Madera barnizada
- Poliuretano expandido integral negro
- Varias bases giratorias

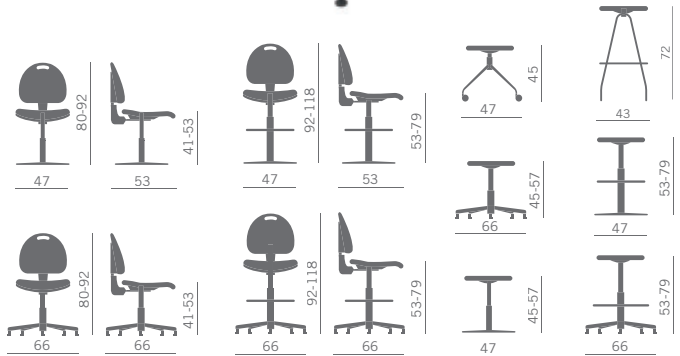

Sgabelli con sedili imbottiti vari colori, con basi girevoli.

Stools with padded seats in various fabric colours and with swivel bases.

Tabourets avec assises garnies en différentes couleurs de tissu, avec piétements pivotants.

Hocker mit Polstersitz erhältlich in verschiedenen Stofffarben, mit drehbaren Gestellen.

Taburetes con asientos tapizados en varios tejidos, con bases giratorias.



Versione bicolore
Two colours version



Base piana bianca
White flat base
d. 48



Base piana cromata
Chromed flat base
d. 48



Base per fissaggio a pavimento
Base to be fixed on the floor

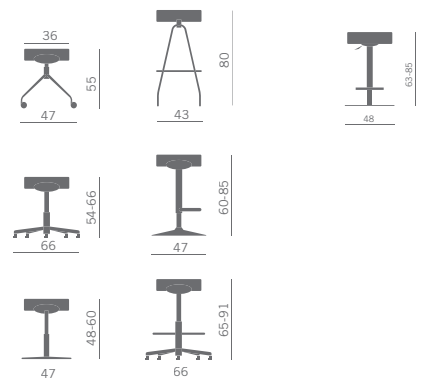

O1 KALEA (SGABELLO-STOOL)



Sgabello

- scocca in polipropilene monocolore
- scocca in polipropilene bicolore
- scocca in polipropilene monocolore o bicolore con sedile imbottito
- scocca in polipropilene, sedile e schienale imbottiti, mono o bicolore

Stool

- one colour polypropylene shell
- two colours polypropylene shell
- one or two colours polypropylene shell with padded seat
- one or two colours polypropylene shell with padded seat backrest

Tabouret

- coque en polypropylène monocolore
- coque en polypropylène deux couleurs
- coque en polypropylène monocolore ou à deux couleurs avec assise rembourrée
- coque en polypropylène, monocolore ou à deux couleurs avec assise et dossier rembourrée

Hoker

- Schale aus Polypropylene einfarbig
- Schale aus Polypropylene zweifarbig
- Schale aus Polypropylene ein- oder zweifarbig mit Sitz gepolstert
- Schale aus Polypropylene ein- oder zweifarbig mit Sitz-Rücken gepolstert

Taburete

- carcasa en polipropileno mono-color
- carcasa en polipropileno bi-color
- carcasa en polipropileno mono-color o bi-color con asiento tapizado
- carcasa en polipropileno mono-color o bi-color con asiento y respaldo tapizado

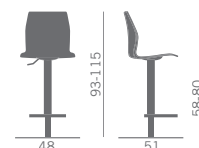
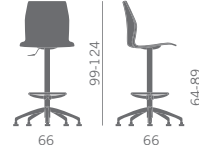
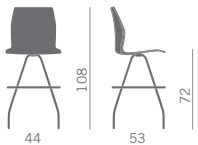
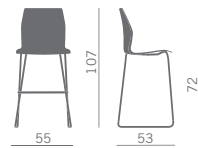
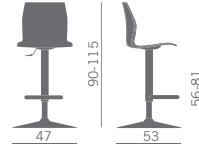
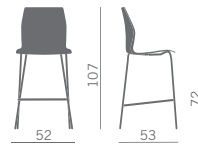

AV
Vern. col. alluminio
Alu painted frame



Monocolore
o bicolore
One or two colours
Sedile imbottito
Padded seat



Polipropilene monocolore
One colour polypropylene
Retroschienale lucido
Glossy backshell



Polipropilene bicolore
Two colours polypropylene
Retroschienale lucido
Glossy backshell



AB
Vern. col. bianco
White painted frame



Sedile-schienale
imbottiti monocolore
o bicolore
Padded seat
backrest one
or two colours



C
Crema (bianco)
Cream (White)

T
Tortora
Dove-colour

V
Verde
Green

R
Rosso
Red



CT
Crema/Tortora
Cream/Dove-colour

CV
Crema/Verde
Cream/Green

CR
Crema/Rosso
Cream/Red



ACC
Cromato
Chromed frame



Base piana bianca
White flat base
d. 48



A
Arancio
Orange

B
Blu
Blue

G
Grigio
Grey

N
Nero
Black



CA
Crema/Arancio
Cream/Orange

CB
Crema/Blu
Cream/Blue

CG
Crema/Grigio
Cream/Grey

CN
Crema/Nero
Cream/Black



Base per fissaggio
a pavimento
Base to be fixed
on the floor



Base piana cromata
Chromed flat base
d. 48

KICCA (SGABELLO-STOOL)



KICCA Modello registrato - Registered model

Sgabello:

- scocca in polipropilene in 8 colori
- scocca in polipropilene con sedile imbottito
- scocca in polipropilene con sedile e schienale imbottito

Stool:

- polypropylene shell available in 8 colours
- polypropylene shell with padded seat
- polypropylene shell with padded seat and back.

Tabouret:

- coque en polypropylène disponible en 8 couleurs
- coque en polypropylène avec assise rembourrée
- coque en polypropylène avec assise et dossier rembourré

Hocker:

- Schale aus Polypropylen lieferbar in 8 Farben
- Polstersitz
- Sitz und Rücken gepolstert

Taburete:

- Carcasa en polipropileno disponible en 8 colores
- Carcasa en polipropileno con asiento tapizado
- Carcasa en polipropileno con asiento y respaldo tapizados.



AV
Vern. col. alluminio
Alu painted frame



C/sedile imbottito
W/padded seat



Polipropilene
Polypropylene



AB
Vern. col. bianco
White painted frame



C/sedile-schienale
imbottito
W/padded
seat-back

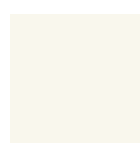

C
Crema (bianco)
Cream (White)
Crème (blanc)
Crème (Weiss)
Crema (blanco)



A
Arancio
Orange
Orange
Orange
Naranja



ACC
Cromato
Chromed frame



Base piana bianca
White flat base
d. 48



T
Tortora
Dove-colour
Tourterelle
Taube
Arena



B
Blu
Blue
Bleu
Blau
Azul



Base per fissaggio a
pavimento
Base to be fixed on
the floor



Base piana cromata
Chromed flat base
d. 48



V
Verde
Green
Vert
Grün
Verde



G
Grigio
Grey
Gris
Grau
Gris



R
Rosso
Red
Rouge
Rot
Rojo



N
Nero
Black
Noir
Schwarz
Negro



A richiesta
Omologazione al fuoco Classe 1IM



Poltrone operative

Task chairs
Sièges opératifs
Drehstühle
Sillas operativas





Poltroncina dattilo nelle versioni: schienale reclinabile, sincron, braccioli fissi, regolabili e orientabili, schienale basso o alto.

Task swivel chair available in the following versions: with reclining backrest, with synchron action, with fixed arms and adjustable rotating arms, low and high backrest.

Siège opératif disponible dans les versions suivantes: avec dossier inclinable, avec mécanisme synchron, avec accoudoirs fixes ou réglables et orientables, dossier bas et haut.

Bürostuhl erhältlich in den folgenden Ausführungen: mit neigbarer Rückenlehne, mit Synchronmechanik, niedrige und hohe Rückenlehne.

Silla operativa en las versiones: respaldo reclinable, sincron, brazos fijos, regulables y orientables, respaldo bajo o alto.

Schienale alto - High back



Schienale basso - Low back



Schienale basso - Low back

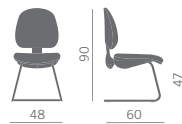

Bracciolo poliuretano
Polyurethane arm



3D Bracciolo regolabile
-allungabile e orientabile
3D Adjustable extensible and rotating arm



A richiesta
Normativa europea EN 1335/TIPO A DL 81/08



A richiesta
Omologazione al fuoco Classe 1M



Poltroncina operativa nelle versioni:

- schienale alto/basso
- schienale regolabile e inclinabile
- braccioli fissi
- regolabili ed orientabili.

Task chair available in the following versions:

- high/low back
- reclining and adjustable backrest
- fixed armrests
- adjustable and rotating armrests.

Siège opératif disponible dans les versions suivantes:

- avec haut/bas dossier
- avec dossier inclinable et réglable
- avec accoudoirs fixes
- avec accoudoirs réglables et orientables.

Bürodrehstuhl erhältlich in den folgenden Ausführungen:

- hohe oder niedrige Rückenlehne
- in Höhe und Neigung verstellbare Rückenlehne
- Armlehnen fest, höhenverstellbar und drehbar.

Silla operativa en las versiones:

- respaldo alto/bajo
- respaldo reclinable y ajustable
- brazos fijos
- brazos ajustables y orientables.

Schienale basso - Low back



Schienale basso - Low back

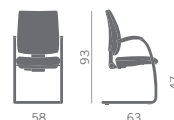
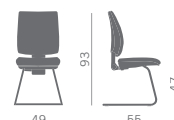

Schienale alto - High back



Bracciolo poliuretano nero
Black polyurethane arm



Bracciolo nylon nero
Black nylon arm



Versione nera
Black version
KX...N



3D Bracciolo regolabile
-allungabile e orientabile
3D Adjustable extensible and
rotating arm



Bracciolo nylon grigio
Grey nylon arm



Versione grigia
Grey version
KX...G



4D Bracciolo regolabile, orientabile,
allungabile, allargabile
4D Adjustable, rotating, extensible,
stretchable arm



Bracciolo nylon bianco
White nylon arm



Versione bianca
White version
KX...B



Poltroncina operativa

- Con o senza braccioli
- Schienale alto o basso
- Retroschienale nero o grigio
- Appoggio lombare regolabile
- Versioni fisse o con vari movimenti synchron.

Task chair

- With or without arms
- High or low backrest
- Black or grey shells
- Adjustable lumbar support
- Fixed versions or with different synchron mechanisms.

Siège opératif

- Avec ou sans accoudoirs
- Avec haut ou bas dossier
- Avec contre-coque dossier noire ou grise
- Avec support lombaire réglable
- Versions fixes ou avec différents mécanismes synchron.

Bürodrehstuhl

- Mit oder ohne Armlehnen
- Mit hoher oder niedriger Rückenlehne
- Rückenschale schwarz oder grau
- Verstellbare Lumbalstütze
- Feststehende Ausführungen oder mit verschiedenen Synchronmechaniken.

Silla operativa

- Con o sin brazos
- Respaldo alto o bajo
- Cubrerrespaldo negro o gris
- Apoyo lumbar ajustable
- Versiones fijas o con diferentes mecanismos synchron

Schienale basso - Low back

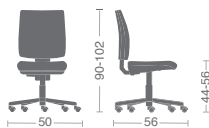

Schienale alto - High back



Schienale basso - Low back

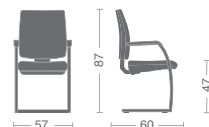

Bracciolo poliuretano
Polyurethane arm



3D Bracciolo regolabile
-allungabile e orientabile
3D Adjustable extensible and
rotating arm



Bracciolo acciaio verniciato alluminio
e poliuretano
Aluminium painted steel
and polyurethane arm



Versione nera
Black version
KK...N



Versione grigia
Grey version
KK...G

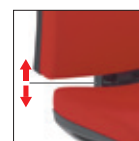

Appoggio lombare
regolabile
Adjustment of the
lumbar support



A richiesta normativa europea
EN 1335/TIPO B DL 81/08



A richiesta
Omologazione al fuoco Classe 1IM

O2 KROMA (MESH)



Poltroncina operativa

- Schienale alto o basso rivestito in rete vari colori
- Braccioli fissi o regolabili

Task chair

- High or low backrest in various colors mesh
- Fixed or adjustable arms

Siège opérative

- Dossier haut ou bas en résille en différents nuances
- Accoudoirs fixes ou réglables

Bürodrehstuhl

- Hohe oder niedrige Rückenlehne
- Feste oder verstellbare Armlehnen

Silla operativa

- Respaldo alto o bajo tapizado con malla en varios colores
- Brazos fijos o regulables

Schienale basso-Low back

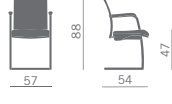
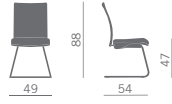

Schienale alto-High back



Bracciolo nylon: nero-grigio-bianco
Nylon arm: black-grey-white



3D Bracciolo regolabile
-allungabile e orientabile
3D Adjustable extensible and rotating arm



Regolazione appoggio lombare
Lumbar support adjustment

Rete poliestere vari colori - Various colors of polyester mesh

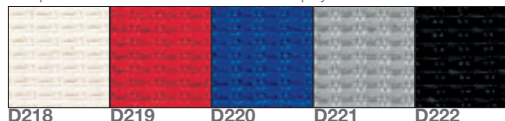

A richiesta
Normativa europea
EN 1335/TIPO B
DL 81/08

O2 KOLOR



Poltroncina operativa nelle versioni:

- con braccioli fissi
- con braccioli regolabili ed orientabili

Operator chair available in the following versions:

- with fixed arms
- with adjustable and rotating arms

Siège opératif disponible dans les versions suivantes:

- avec accoudoirs fixes
- avec accoudoirs réglables et orientables

Bürodrehstuhl lieferbar in folgenden Ausführungen:

- mit festen Armlehnen
- mit höhen- und seitenverstellbaren Armlehnen

Silla operativa en las versiones:

- Con brazos fijos
- Con brazos regulables y orientables

Schienale alto-High back

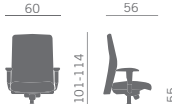

Schienale basso-Low back



Bracciolo regolabile ed orientabile
Adjustable and rotating arm



Bracciolo poliuretano
Polyurethane arm

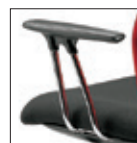

Bracciolo acciaio cromato e poliuretano
Chromed steel and polyurethane arm



Bracciolo verniciato alluminio e poliuretano
Painted aluminium and polyurethane arm



A richiesta
Normativa europea EN 1335/
TIPO B DL 81/08



A richiesta
Omologazione al fuoco Classe 1M



T26
T27

O2 KUPER-EASY MESH · MESH · PLUS LINEAR



KUPER (EASY MESH)



KUPER (MESH)

Poltroncina operativa nelle versioni:

- schienale alto o basso
- struttura portante nera o bianca
- sedile imbottito, schienale in rete vari colori
- sedile e schienale imbottiti

Task chair available in the following versions:

- high or low back
- white or black frame's backrest
- padded seat, backrest in different mesh's colors
- padded seat and back

Siège opératif disponible avec:

- dossier haut ou bas
- structure dossier blanche ou noire
- assise garnie, dossier en résille en différentes nuances.
- assise et dossier garnis

Bürostuhl erhältlich in den folgenden Ausführungen:

- Hohe oder niedrige Rückenlehne
- Trägerstruktur schwarz oder weiß
- Polstersitz, Rücken mit Netzbespannung in verschiedenen Farben
- Sitz und Rücken gepolstert

Silla operativa en las versiones:

- respaldo alto o bajo
- estructura portante negra o blanca
- asiento relleno y tapizado,
- asiento y respaldo rellenos y tapizados



Kuper (easy mesh)
Kuper (mesh)
Kuper (plus linear)
Schienale alto - High back

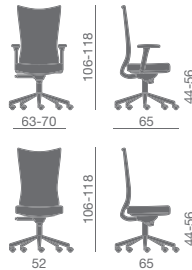

Kuper (mesh)
Kuper (plus linear)
Schienale basso - Low back

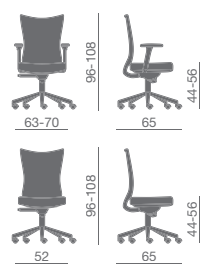

Kuper (easy mesh)
Schienale basso - Low back

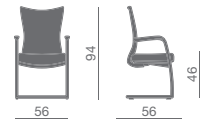

Kuper (easy mesh)

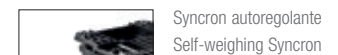

Kuper (easy mesh)
Kuper (mesh)
Kuper (plus linear)

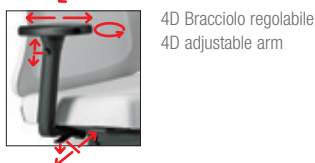

KUPER (EASY MESH)
KUPER (MESH)
Schienale rete
Mesh backrest

Rete poliestere vari colori - Various colors of polyester mesh





Poltrona operativa nelle versioni:

- schienale regolabile in altezza
- struttura schienale nera con rete nera D222
- struttura schienale grigia con rete nera D222
- appoggio lombare regolabile in altezza con lo schienale e in 2 posizioni di profondità
- appoggiatesta regolabile in altezza e orientabile
- Versione Plus: schienale imbottito c/struttura nera o grigia

Task chair:

- height adjustable back
- black back frame with black mesh D222
- grey back frame with black mesh D222
- adjustable lumbar support in height and 2 depth positions
- adjustable and rotating headrest
- Plus version: padded back with black or grey structure

Siège operative dans les versions:

- dossier réglable en hauteur
- contre-coque noire avec résille noire D222
- contre-coque grise avec résille noire D222
- support lombaire réglable en hauteur et en profondeur (2 positions)
- appui-tête réglable en hauteur et pivotant
- Version Plus: dossier rembourré avec contre-coque noire ou grise

Bürosessel in den folgenden Ausführungen erhältlich:

- Höhenverstellbare Rückenlehne
- Rückenträger schwarz mit schwarzer Netzbespannung D222
- Rückenträger grau mit schwarzer Netzbespannung D222
- Lumbalstütze, verstellbar in der Höhe mit dem Rücken und in der Tiefe in 2 Stellungen
- Kopfstütze höhenverstellbar und drehbar
- Ausführung Plus; Gepolsterte Rückenlehne mit Struktur schwarz oder grau

Sillón operativo en las versiones:

- respaldo ajustable en altura
- estructura respaldo negra con malla negra D222
- estructura respaldo gris con malla negra D222
- apoyo lumbar regulable en altura con el respaldo y en 2 posiciones de profundidad
- Reposacabezas regulable en altura y orientable
- Versión Plus: respaldo relleno con estructura negra o gris



A richiesta
Normativa europea
EN 1335/TIPO B
DL 81/08



Appoggiatesta regolabile in altezza e orientabile
Adjustable and rotating headrest



Appoggio lombare regolabile in altezza e in 2 posizioni di profondità
Adjustable lumbar support in height and 2 depth positions

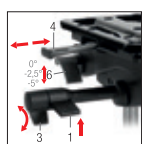

Syncron + Traslatore + Varia
Syncron + Slide System + Varia

- 1 Leva di alzo seduta/Seat height adjustment
- 2 Blocco e sblocco oscillazione/Tilt movement control
- 3 Regolazione rapida di intensità di carica in 10 diverse posizioni con 1/4 di giro della leva
Fast tension adjustment in 10 different positions by 1/4 of lever turn
- 4 Leva regolazione profondità seduta/Seat depth adjustment
- 6 Variatore angolo sedile (inclinazione negativa 0°/-2,5°/-5°) attitude variator
(Negative inclination 0°/-2,5°/-5°)



Bracciolo poliuretano
Polyurethane arm



3D Bracciolo regolabile allungabile e orientabile
3D Adjustable extensible and rotating arm



4D Bracciolo regolabile, orientabile, allungabile, allargabile
4D Adjustable, rotating, extensible, stretchable arm



Bracciolo nylon grigio o nero
Grey or black nylon arm



Struttura schienale nero
Black backrest structure
Rete nera D222
Black mesh D222



Struttura schienale grigio
Grey backrest structure
Rete nera D222
Black mesh D222



Versione Plus:
schienale imbottito
Plus version:
padded backrest



Sedia/Chair
Scocca solo nera
Schienale rete D222 o imbottito
Only black shell
Mesh D222 or padded backrest



Poltroncina operativa

- Schienale alto o basso
- Schienale in rete o rivestito
- Braccioli fissi o regolabili

Task chair

- High or low back
- Backrest in mesh or upholstered.
- Fixed or adjustable arms.

Siège opérative

- Dossier haut ou bas
- Dossier en résille ou revêtu.
- Accoudoirs fixes ou réglables.

Buerodrehstuhl

- Hohe oder niedrige Rückenlehne
- Rücken mit Netzbespannung oder gepolstert
- Feste oder verstellbare Armlehnen

Silla operativa

- Respaldo alto o bajo
- Respaldo en malla o tapizado
- Brazos fijos o regulables

Schienale alto-High back



Schienale basso-Low back



Schienale basso-Low back

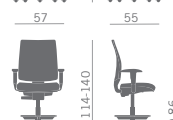
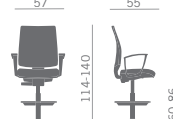
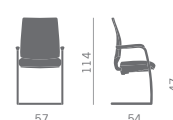

Bracciolo poliuretano
Polyurethane arm



3D Bracciolo regolabile
-allungabile e orientabile
3D Adjustable extensible and rotating arm



4D Bracciolo regolabile,
orientabile, allungabile,
allargabile
4D Adjustable, rotating,
extensible, stretchable arm



Bracciolo acciaio
cromato e poliuretano
Chromed steel and
polyurethane arm



Appoggio lombare
Lumbar support



Schienale imbottito
Padded backrest



Schienale rete
Mesh backrest

Rete poliestere vari colori - Various colors of polyester mesh

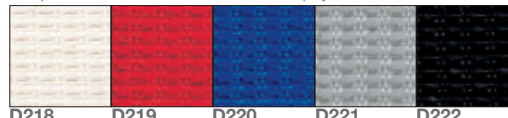

A richiesta normativa europea EN 1335/
TIPO B - DL 81/08



A richiesta
Omologazione al fuoco Classe 11M
con schienale imbottito



Poltroncina operativa e semidirezionale nelle versioni:
 - schienale alto
 - schienale basso.

Task and executive chair available in the following versions:
 - with high back
 - with low back.

Siège opératif et de direction disponible dans les versions suivantes:
 - avec haut dossier
 - avec bas dossier.

Arbeits- und Direktionssessel in den folgenden Ausführungen:
 - hohe Rückenlehne
 - niedrige Rückenlehne.

Silla operativa y sillón semi-direccional en las versiones:
 - respaldo alto
 - respaldo bajo.

Schienale alto - High back

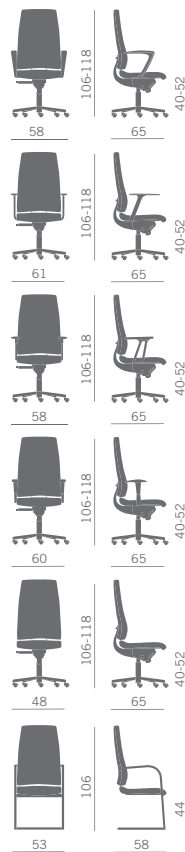

Schienale basso - Low back

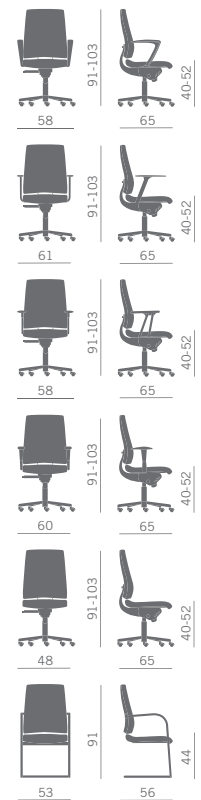

Codice/Code KVT075

Normativa BS 5459-2:2000 -
 Utilizzo 24 ore e peso kg 150
 24 hours use, till 150 kg weight
 user



Bracciolo in acciaio verniciato alluminio
 e poliuretano
 Aluminium painted steel and
 polyurethane arm



Bracciolo poliuretano
 Polyurethane arm



Bracciolo alluminio, con
 soprabracciolo imbottito o
 poliuretano
 Aluminium arm, padded or
 polyurethane top



Appoggio lombare regolabile
 Adjustment of the lumbar support
KVR...



4D Bracciolo regolabile, orientabile,
 allungabile, allargabile
 4D Adjustable, rotating, extensible,
 stretchable arm





Poltroncina operativa di innovativo design supportata da un sistema in acciaio con sovrainiezione di poliuretano espanso integrale antiurto.

Operator chair with innovative design supported by an internal steel structure covered with injected expanded polyurethane, shockproof.

Siège opératif au design novateur supporté par une armature en acier recouverte (sur-injections) de polyuréthane integral, antichoc.

Bürodrehstuhl mit innovativem Design getragen von einem stoffsicheren Stahlgestell, unmantelt mit Polyurethan-Kaltschaum.

Silla operativa de nuevo diseño soportada por un sistema de acero con sobre-inyección de poliuretano expandido integral antishock.

Sedile imbottito - Schienale rete
Padded seat - Mesh backrest

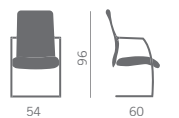
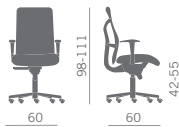

3D Bracciolo regolabile
-allungabile e orientabile
3D Adjustable extensible and rotating arm



Bracciolo acciaio cromato e poliuretano
Chromed steel and polyurethane arm



Bracciolo verniciato alluminio e poliuretano
Aluminium painted and polyurethane arm

Appoggio lombare regolabile
Adjustment of the lumbar support



Schienale rete
Mesh backrest

Rete poliestere vari colori - Various colors of polyester mesh

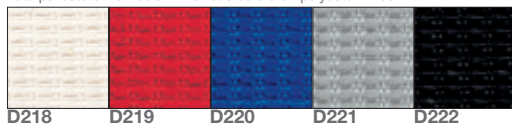

KORIAM (MESH) · KORIAM (PLUS)

(FLEXING BACKREST)



Korium (mesh)



Korium (plus)

Poltrona operativa caratterizzata da:

- schienale alto e basso
- struttura schienale in polipropilene nero o grigio
- schienale in rete

Nelle versioni "Plus" lo schienale è imbottito con struttura nera o grigia e rete di supporto nera.

Task swivel chair available in the following versions:

- high and low backrest
- backrest structure in black or grey polypropylene
- backrest with mesh

In the "Plus" versions the backrest is upholstered.

The backrest structure can be black or grey and the supporting mesh only black.

Siège opératif disponible dans les versions:

- dossier haut et bas
- structure du dossier en polypropylène noir ou gris
- dossier en résille

Dans les versions "Plus", le dossier est rembourré avec structure du dossier noire ou grise et résille portante noire.

Bürodrehstuhl lieferbar in folgenden Ausführungen:

- hohe oder niedrige Rückenlehne
- Rückenräger aus Polypropylen schwarz oder grau
- Rückenlehne aus Membran

In den Ausführungen Plus hat die Rückenlehne, aus schwarzem Membran mit schwarzem bzw. grauem Rückenräger, zusätzlich eine Aufpolsterung.

Silla operativa en las versiones:

- respaldo alto o bajo
- estructura respaldo en polipropileno negro o gris
- respaldo en malla

En la versión "Plus" el respaldo es tapizado, la estructura del respaldo puede ser negra o gris y la malla de soporte solo negra.

Korium (mesh)

Schienale in rete
Backrest in mesh

- * Struttura schienale nera - Black backrest structure
- ** Struttura schienale grigia - Grey backrest structure

KRU1..
KRU3..

Korium (plus)

Schienale imbottito - Padded backrest

(con supporto in rete nera-with support in black mesh)

- * Struttura schienale nera - Black backrest structure
- ** Struttura schienale grigia - Grey backrest structure

KRU2..
KRU4..



Bracciolo poliuretano
Polyurethane arm



Schienale flessibile
Flexing backrest



Bracciolo alluminio, con soprabracciolo imbottito o poliuretano nero
Aluminium arm, padded or black polyurethane top



* Struttura schienale nera
Black backrest structure
KRU1..
KRU2..



KORIAM (PLUS)
Schienale imbottito
Padded backrest



3D Bracciolo regolabile
-allungabile e orientabile
3D Adjustable extensible and rotating arm



** Struttura schienale grigia
Grey backrest structure
KRU3..
KRU4..



KORIAM (MESH)
Schienale rete
Mesh backrest



4D Bracciolo regolabile, orientabile, allungabile, allargabile
4D Adjustable, rotating, extensible, stretchable arm

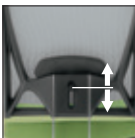

KRU150
Appoggio lombare regolabile
Adjustment of the lumbar support

Rete poliestere vari colori - Various colors of polyester mesh



D218 D219 D220 D221 D222



Poltrone direzionali

Executive and managerial swivel chairs

Fauteuils direction

Chefseessel

Sillones direccionales





Programma di poltroncine di raffinato design, con schienale in rete, supportato da profili in alluminio lucido.

Series of armchairs with elegant design with backrest is mesh supported by polished aluminium profiles.

Série de fauteuil au lignes raffinés avec dossier en résille sur des profiles en aluminium poli.

Die Kollektion bietet anspruchsvolle Designessel mit Rückenlehne aus Membran umrahmt von Profilen aus poliertem Aluminium.

Programa de sillones de refinado diseño, con respaldo en malla soportado por perfiles en aluminio pulido.

Schienale alto - High back

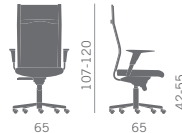

Schienale basso - Low back

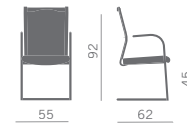
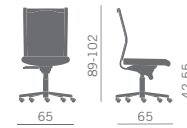
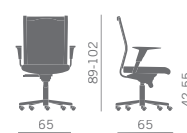

Bracciolo poliuretano
Polyurethane arm



Bracciolo alluminio, con soprabracciolo imbottito o poliuretano nero
Aluminium arm, padded or black polyurethane top



4D Bracciolo regolabile, orientabile, allungabile, allargabile
4D Adjustable, rotating, extensible, stretchable arm



Schienale rete
Mesh backrest

Rete poliestere vari colori - Various colors of polyester mesh

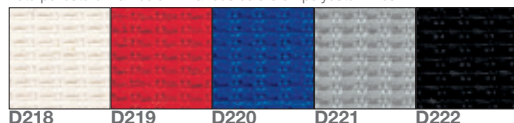

O3 KOSMO PLUS



Poltrona direzionale con schienale supportato da una rete nera e profili in alluminio lucido con cuscino removibile, rivestito come il sedile.

Executive armchair with polished aluminium profiles and black mesh backrest with upper removable cushion upholstered like the seat.

Fauteuil direction: structure dossier en profilés d'aluminium poli et résille noire avec coussin amovible, revêtu idem assise.

Chefsessel mit Rückenlehne getragen von Profilen aus poliertem Aluminium und schwarzem Membran, mit abnehmbarem Kissen gepolstert wie den Sitz.

Sillón direccional con respaldo tapizado soportado por perfiles en aluminio pulido y malla negra con cojin intercambiable, tapizado como el asiento.

Schienale basso - Low back

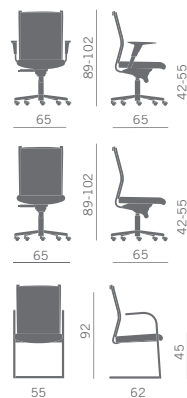

Schienale alto - High back

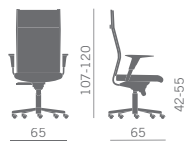

Portagiacca/Jacket hook
Cintre porte veste
Sakkobügel/Perchero
KSM151

Regolazione appoggio lombare
Adjustment of lumbar support
Réglage du support lombaire
Einstellung der Lumbalstütze
Regulación apoyo lumbar

KSM150

Bracciolo poliuretano
Polyurethane arm

Bracciolo alluminio, con soprabracciolo imbottito o poliuretano nero
Aluminium arm, padded or black polyurethane top

4D Bracciolo regolabile, orientabile, allungabile, allargabile

4D Adjustable, rotating, extensible, stretchable arm



A richiesta
Normativa europea EN 1335

A richiesta
Omologazione al fuoco Classe 1IM

O3 KOSMO TOP



Poltrona direzionale con sedile e schienale rivestiti a scelta e bordi laterali in fintappele nera; profili schienale in alluminio lucido.

Executive armchair with seat and back fully upholstered and lateral sides in imitation leather; backrest profiles in polished aluminium.

Fauteuil direction avec assise et dossier avec revêtement à définir et parties latérales en similicuir noir; profils dossier en aluminium poli.

Chefsessel mit Sitz und Rückenlehne gepolstert und seitliche Profile aus schwarzem Kunstleder; Rückenprofile aus poliertem Aluminium

Sillón direccional con asiento y respaldo tapizados y rematados bordes laterales en piel sintética negra; perfiles respaldo en aluminio pulido.

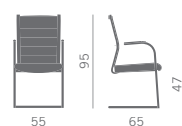
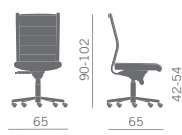
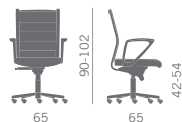

Portagiacca/Jacket hook
Cintre porte veste
Sakkobügel/Perchero
KSM151

Regolazione appoggio lombare
Adjustment of lumbar support
Réglage du support lombaire
Einstellung der Lumbalstütze
Regulación apoyo lumbar

KSM150



Bracciolo poliuretano
Polyurethane arm



Bracciolo alluminio, con soprabracciolo imbottito o poliuretano nero
Aluminium arm, padded or black polyurethane top



4D Bracciolo regolabile, orientabile, allungabile, allargabile

4D Adjustable, rotating, extensible, stretchable arm

Normativa europea
EN 1335



Poltrona direzionale

- Struttura unica portante in acciaio cromato o bianco
- Schienale alto e basso
- Sedile e schienale in rete poliestere vari colori
- Sedile e schienale rivestito in vari colori e soluzioni
- Versioni fisse, oscillanti, oscillanti "knee-tilt"

Executive armchair

- Sole supporting frame in chromed or white steel
- High or low backrest
- Seat and back in various colors of polyester mesh
- Seat and back upholstered in various colors and versions
- Fixed frame, tilting or "knee-tilt" mechanism

Fauteuil direction

- Structure unique de support en acier chromé ou blanc
- Dossier haut et bas
- Assise et dossier en résille polyester de différents couleurs
- Assise et dossier revêtus en différentes nuances et versions
- Versions fixes, basculantes, basculantes "knee-tilt"

Chefsessel

- Tragende Struktur aus Stahl verchromt oder weiß
- Hohe und niedrige Rückenlehne
- Sitz+Rücken mit Netzbespannung aus Polyester in verschiedenen Farben
- Sitz+Rücken gepolstert in verschiedenen Farben und Ausführungen
- Verschiedene Ausführungen: fest, Neigungsbewegung, Neigungsbewegung "Knee-tilt"

Sillón direccional

- Estructura única de soporte en acero cromado o blanco
- Respaldo alto e bajo
- Asiento y respaldo en malla poliéster varios colores
- Asiento y respaldo tapizado en varios colores y soluciones
- Versiones fijas, "tilt", "knee-tilt"

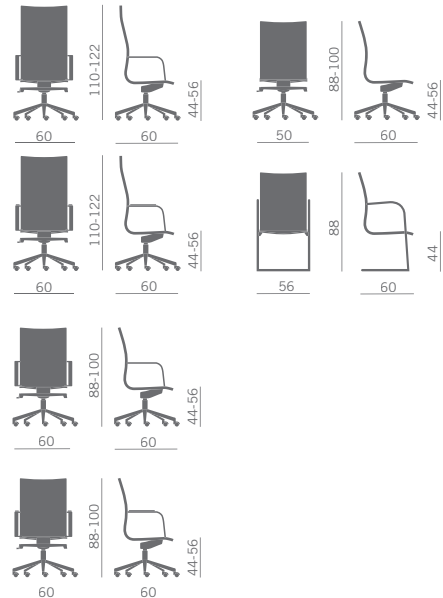

KU..C.
Bracciolo cromato
Chromed steel



Telaio e braccioli verniciati bianco
White painted frame and arms



Kruna plus (linear) L
Imbottitura "lineare"
"Linear" pad



Kruna plus (rhomboidal) R
Imbottitura "romboidale"
"Rhomboidal" pad



KU..P.
Bracciolo cromato, con soprabracciolo poliuretano nero
Chromed steel, with black polyurethane arm top

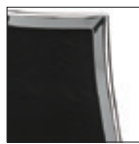

Telaio cromato
Chromed frame

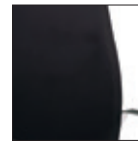

Kruna (mesh)
Sedile/schienale rete
Mesh seat/backrest



TU..T.
Bracciolo cromato, con soprabracciolo imbottito
Chromed steel, with padded arm top

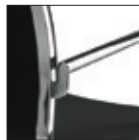

Telaio slitta cromato
Chromed sled frame

Kruna (mesh) (sedile/schienale rete - Mesh seat/backrest)

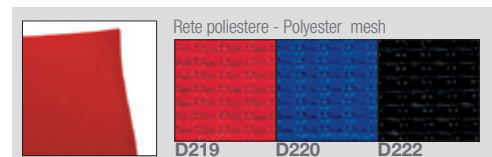



Poltrona direzionale ergonomica con sedile e schienale interamente imbottiti e rivestiti, inserto schienale in acciaio e varie soluzioni di basi e braccioli.

Ergonomic executive armchair with seat and back fully padded and upholstered, bottom backrest steel insert and many options for bases and armrests.

Fauteuil direction ergonomique avec assise et dossier garnis et entièrement revêtus, structure inférieur dossier avec insert en acier.

Direktionssessel mit Sitz+Rücken komplett umpolstert, Rückenschale aus Stahl und erhältlich in verschiedenen Lösungen von Gestellen und Armlehnen.

Sillón direccional ergonómico con asiento y respaldo totalmente acolchados, incrustación de acero en la parte trasera así como y diferentes soluciones de bases y brazos.

Schienale alto - High back

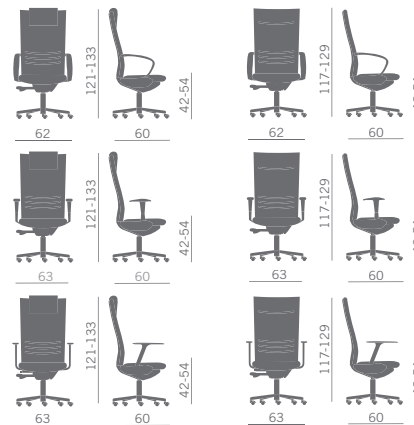

Schienale basso - Low back

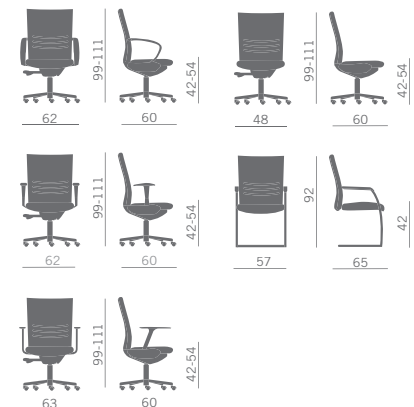

Particolare appoggiatesta
Headrest detail



Bracciolo alluminio, con
soprabracciolo imbottito
o poliuretano nero
Aluminium arm, padded
or black polyurethane top



Bracciolo flessibile
in poliuretano nero
Flexible black
polyurethane arm



Appoggio lombare
Lumbar support
KGR...

O3 KONCORD · KONCORD PLUS



Koncord plus



Koncord



Poltrona direzionale ergonomica con varie soluzioni e caratterizzata da 2 versioni:
 - Koncord: sedile e schienale imbottiti
 - Koncord plus: sedile e schienale imbottiti e con sopra riportato un cuscino nello stesso rivestimento

Ergonomic executive armchair with many options and 2 main versions:
 - Koncord: padded seat and back
 - Koncord plus: padded seat and back with an extra fully upholstered fixed cushion.

Fauteuil direction ergonomique avec différentes options et 2 variantes:
 - Koncord: assise et dossier garnis
 - Koncord plus: assise et dossier garnis avec coussin supplémentaire revêtu idem coque.

Chefsessel erhältlich in 2 Ausführungen:
 - Koncord Sitz+Rücken gepolstert
 - Koncord plus: Sitz und Rücken gepolstert und mit abnehmbaren Kissen in dem gleichen Bezug.

Sillón direccional ergonómico disponible en 2 versiones:
 - Koncord: asiento y respaldo acolchados
 - Koncord plus: asiento y respaldo acolchados con doble almohadillado tapizado en el mismo tejido.

Koncord - Koncord Plus
 Presidenziali - High back



Koncord
 Operative - Clerical

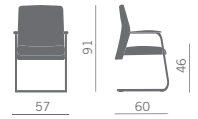

Soprabracciolo imbottito
 Padded top arm



Bracciolo poliuretano
 Polyurethane arm



Bracciolo regolabile ed orientabile
 Adjustable and rotating arm

CATAS A richiesta Normativa europea EN 1335/ TIPO C
 A richiesta Omologazione al fuoco Classe 1IM

O3 KAMELIA



Poltrona direzionale
 - Schienale alto, medio o basso
 - Braccioli imbottiti strutturati con lo schienale
 - Varie versioni fisse o con movimento synchron

Executive armchair
 - With high, medium or low backrest.
 - Padded and upholstered arms integrated with the shell.
 - Various frames versions with fixed bases or with synchron movement.

Fauteuil direction
 - Dossier haut, moyen ou bas
 - Accoudoirs garnis et revêtus intégrés dans la structure de la coque.
 - Plusieurs plétements disponibles fixes ou avec mouvement synchron

Chefsessel
 - Hohe, mittlere und niedrige Rückenlehne
 - Gepolsterte Armlehnen an der Rückenlehne befestigt
 - Verschiedene Ausführungen fest oder mit Synchronmechanik

Sillón direccional
 - Respaldo alto, medio o bajo
 - Brazos tapizados integrados en el respaldo
 - Varias versiones fijas o con mecanismo synchron



A richiesta omologazione al fuoco Classe 1IM

CATAS A richiesta Normativa europea EN 1335/ TIPO C

O3 KOMPASSO · KOMPASSO MESH



Poltrona direzionale con struttura schienale in poliuretano integrale antiurto nero e interno in rete o imbottito.

Executive armchair with frame backrest in black integral anti-shock polyurethane and central part in mesh or fully padded.

Fauteuil direction avec structure périphérique du dossier en polyuréthane intégral antichoc noir - partie centrale en résille ou garnie.

Direktionssessel mit stossicherem Rückenträger aus schwarzem formstabilem Polyurethan und Rückenlehne mit Membran oder gepolstert.

Sillón direccional con estructura respaldo en poliuretano integral anti-choque negro tapizado en malla o acolchado.

Schienale alto - High back

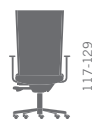
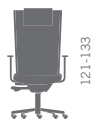
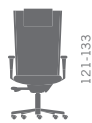

Schienale basso - Low back

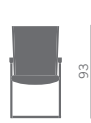

Kompasso
Schienale imbottito
Padded backrest



Kompasso mesh
Schienale rete
Mesh backrest

Rete poliestere vari colori - Various colors of polyester mesh

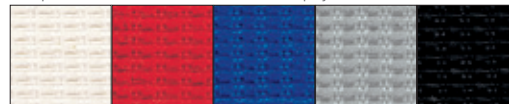

A richiesta
Omologazione al fuoco Classe 1M

O3 KIMERA - KIMERA (RHOMBOIDAL)



Imbottitura "romboidale"
"Rhomboidal" pad

... raffinato design per l'ufficio presidenziale.

... refined design for managerial office.

... d'un design raffiné pour bureau de direction

... raffiniertes Design geeignet für Chefsbüros

... diseño refinado para la oficina de dirección.



A richiesta
Normativa europea EN 1335/ TIPO C



A richiesta omologazione al fuoco Classe 1M



T40
T41



Poltrona direzionale con braccioli in poliuretano nero, girevole o su telaio a slitta

Executive armchair with arms in black polyurethane, with swivel or sled frames.

Fauteuil direction avec accoudoirs en polyuréthane intégral noir, bases pivotantes ou luge.

Direktionssessel mit Armlehnen aus schwarzem Polyurethan, mit Gestell drehbar oder freischwinger.

Sillón direccional con brazos en poliuretano negro, con base giratoria o base patín.



Bracciolo poliuretano
Polyurethane arm



A richiesta
Omologazione al fuoco Classe 11M



Poltrona direzionale con braccioli in poliuretano nero, girevole o su telaio a slitta

Executive armchair with arms in black polyurethane, with swivel or sled frames.

Fauteuil direction avec accoudoirs en polyuréthane intégral noir, bases pivotantes ou luge.

Direktionssessel mit Armlehnen aus schwarzem Polyurethan, mit Gestell drehbar oder freischwinger.

Sillón direccional con brazos en poliuretano negro, con base giratoria o base patín.

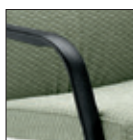
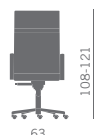

Bracciolo poliuretano
Polyurethane arm



A richiesta
Normativa europea EN 1335 TIPO C

O3 KLASSIC



Poltrona direzionale con avvolgente scocca imbottita e braccioli in acciaio cromato o poliuretano rivestiti.

Executive armchair with enveloping padded shell and chromed arms or in upholstered polyurethane.

Fauteuil direction avec enveloppante coque garnie et revêtue et accoudoirs en acier chromé ou en polyuréthane avec manchettes tapissées.

Direktionsessel mit gepolsterter Monoblockschale und mit Armlehnen aus verchromtem Stahl oder aus Polyurethan mit Polsterauflage.

Sillón direccional con carcasa envolvente acolchada y brazos en acero cromado o en poliuretano tapizados.

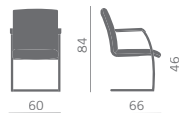

Bracciolo cromato con soprabracciolo imbottito
Chromed with padded top arm



O3 KLARO



Poltrona direzionale con cuscino aggiuntivo rivestito su sedile e schienale, disponibile nelle versioni girevoli e su telaio fisso a slitta.

Executive armchair with extra upholstered cushion for back and seat, available in the versions with swivel bases or sled frames.

Fauteuil direction garni avec matelassage supplémentaires entièrement revêtu, disponible dans les versions pivotantes ou bien luge.

Direktionsessel mit gepolsterem Auflagekissen auf dem Sitz und auf der Rückenlehne, verfügbar in den drehbaren Ausführungen, oder mit Freischwingergestell.

Sillón direccional con cojín tapizado arriba asiento y respaldo, disponible en las versiones giratorias con o sin basculante y con base patín.

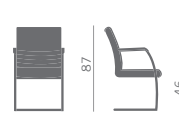

A richiesta
Normativa europea EN 1335 TIPO C



A richiesta
Omologazione al fuoco Classe 11M



T42
T43



Riunione · attesa · travi · tavoli

Meeting - lounge seating, benches, tables

Sièges attente-réunion, poutres, tables

Polstergruppen, bänke, tische

Reunión, espera, bancadas, mesas

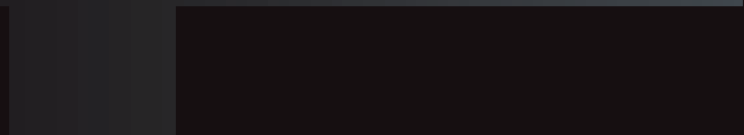

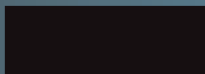

O4 KUADRELLA



Poltroncina multiuso per l'ufficio, l'attesa e la riunione nelle versioni:

- telaio 4-gambe verniciato alluminio con ruote o piedini
- base acciaio cromato fissa 4 razze
- con o senza schienalino.

Multifunctional armchair suitable for office, waiting and meeting areas available in the following versions:

- with 4-legs painted aluminium steel frame, equipped with castors or feet
- 4-stars fixed base in chromed steel
- with or without small backrest.

Fauteuil à multi-usages pour le bureau, l'attente et la salle de réunion disponible dans les versions suivantes:

- sur piétement 4-pieds en acier époxy aluminium avec roulettes ou patins
- piétement fixe à 4-branches en acier chromé
- avec ou sans petit dossier.

Mehrzweckessel für Büro, Empfang und Konferenzraum mit zahlreichen Optionen:

- mit Vierfußgestell aus alusilber lackiertem Stahl mit Rollen oder Gleitern
- Sternförmiges 4-Fuß-Gestell aus verchromtem Stahl
- mit oder ohne schmaler Rückenlehne.

Sillón multiuso para oficina, espera y reunión en las versiones:

- estructura 4 patas pintada aluminio con ruedas o topes deslizantes
- base fija de 4 radios en acero cromado
- con o sin pequeño respaldo.

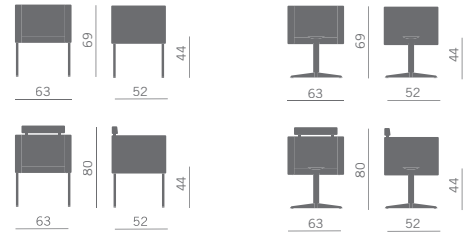

 A richiesta
Omologazione al fuoco Classe 1M

Coppia di agganci
Linking devices

O4 KAMPUS (POZZETTO)



Poltroncine multiuso per zone attesa, riunione o visitatore nelle versioni:

- cuoietto nero, bordeaux
- tessuti e pelli

Multifunctional armchair for waiting and meeting areas or as visitor chairs available in the following versions:

- genuine black, burgundy "cuoietto"
- fabrics and leathers

Chaise multi-usages pour l'attente, la réunion ou les visiteurs disponible dans les versions suivantes:

- en vrai cuir sellier noir, bordeaux
- tissus et cuirs

Mehrzweckessel, geeignet als Besucherstuhl oder für Empfangs- bzw. Konferenzräume, lieferbar in den Ausführungen:

- echtes Kernleder: schwarz, bordeauxrot
- Bezugsstoffe und Leder

Sillones multiuso para zonas de espera, reunión o visita en las versiones:

- cuero negro, granate
- tela y piel.

Kampus (pozzetto)

Versioni "Cuoietto"
"Cuoietto" versions



Nero
Black

Bordeaux
Bordeaux



Versione imbottita
Padded version

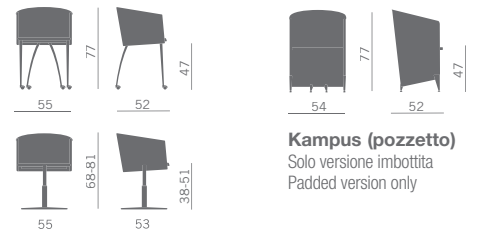

Kampus (pozzetto)

Solo versione imbottita
Padded version only



 A richiesta Kampus 2 versioni imbottite:
omologazione al fuoco Classe 1M

O4 KRIBIO



Poltroncina multiuso per l'ufficio, l'attesa e riunione, nelle versioni:

- basi girevoli
- telaio 4 gambe verniciato alluminio con ruote
- telaio 4 gambe verniciato alluminio con piedini.

Multifunctional chair suitable for use office, waiting area, and meeting room; available in the following versions:

- with swivel bases
- with 4-legs aluminium painted base with wheels
- with 4 legs aluminium painted base with feet.

Chaise à différents usages pour le bureau, la salle d'attente et de réunion disponible dans les versions suivantes:

- pivotantes
- avec piétement 4-pieds epoxy aluminium avec roulettes
- avec piétement 4-pieds epoxy aluminium avec patins.

Mehrzweckstuhl für das Büro, den Empfang, den Konferenzraum erhältlich in drei Ausführungen:

- Drehstühle
- Vierfüßgestell, silbergrau lackiert, mit Rollen
- Vierfüßgestell, silbergrau lackiert, mit Gleitern.

Sillón multiuso para oficina, espera y reunión, en las versiones:

- bases giratorias
- estructura 4 patas pintada aluminio con ruedas
- estructura 4 patas pintada aluminio con topes deslizantes.

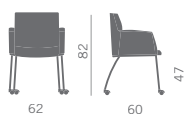
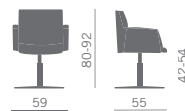
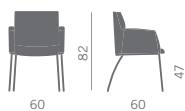

A richiesta
Omologazione al fuoco Classe 11M

O4 KAMEO



Poltroncina multiuso per zone attesa e riunione nelle versioni:

- telaio 4 gambe cromato
- telaio a slitta cromato
- base girevole.

Armchair suitable for waiting area and meeting room, available in the following versions:

- with chromed 4-legs frame
- with chromed sled base
- with swivel base.

Chaise à différents usages pour la salle d'attente et de réunion, disponible dans les versions suivantes:

- avec piétement 4-pieds chromé
- avec piétement luge chromé
- avec piétement pivotant.

Mehrzweckstuhl für Empfangs- und Konferenzräume, lieferbar in folgenden Ausführungen:

- mit verchromtem Vierfüßgestell
- mit verchromtem Freischwingersgestell
- mit Fußkreuz.

Silla multiuso para salas de espera y reunión en las versiones:

- estructura 4 patas cromada
- base patín cromada
- base giratoria.

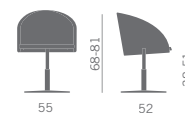
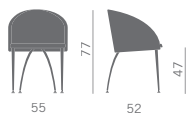
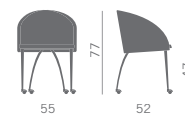
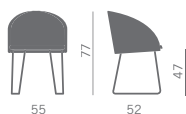

A richiesta
Omologazione al fuoco Classe 11M



T46
T47

O4 KLIPP



Poltroncina multiuso con fianchi fissi o pieghevoli per sale riunione, conferenza.

Polyfunctional armchair with fixed or pliable side arms suitable for meeting and conference rooms.

Bridge fixe ou pliant à usage polyvalent pour les lieux d'accueil, les réunions.

Fester oder Klappbarer Mehrzwecksessel ideal fuer Ihren Empfangs-/Konferenzraum bzwz.

Butaca multiuso con costados fijos o plegables para salas reuniones, conferencia.



Con ruote
With castors

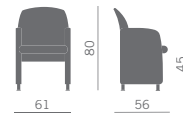

Con piedini
With feet

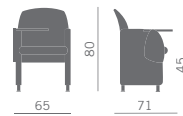

C/tavoletta antipanico
W/antipanic tablet

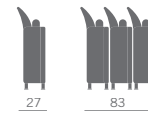

Versione fianchi pieghevoli
Pliable side arms version



A richiesta
Omologazione al fuoco Classe 1IM

O4 KASUAL



Poltroncina per zone attesa, con scocca unica in acciaio e poliuretano ignifugo e agganciabile.

Lounge chair for waiting areas with polyurethane and steel single shell, equipped with linking device.

Chaufeuse pour salle attente avec structure en acier et polyuréthane injecté à froid non-feu, équipée d'un système d'accrochage.

Polstersessel ideal für Warteraum, mit Monoschale aus Stahl und feuerhemmendem Polyurethanschaum.

Butaca enganachable para areas de espera con carcasa en acero y poliuretano ignifugo.

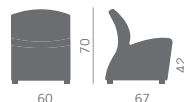

A richiesta
Omologazione al fuoco Classe 1IM



Poltrona per zona attesa e conversazione con:

- base Ø 580 mm in acciaio inox
- base 4 razze in acciaio cromato o alluminio
- base 4 gambe in acciaio verniciato color alluminio

Armchair for waiting and conversation area with:

- Frame Ø 580 mm in stainless steel
- 4-stars frame in chromed or aluminium painted steel
- 4 legs in aluminium painted steel

Chaufeuse pour l'attente et la conversation avec:

- Piétement Ø 580 mm en acier inox
- Piétement à 4-branches en acier chromé ou aluminium
- Piétement à 4-pieds en acier verni epoxy aluminium

Sessel geeignet für Empfangs- bzw. Konferenzräume:

- Gestell Ø 580 mm aus rostfreiem Edelstahl
- 4-Fußkreuz, verchromt oder Aluminium
- Vierfüßgestell aus alulackiertem Stahl

Sillón para espera y conversación:

- Estructura Ø 580 mm en acero inoxidable
- Estructura a 4 patas en acero cromado o aluminio
- Estructura a 4 patas en acero pintado aluminio

Girevole o fissa cromata
Swivel or fixed chromed



Fissa/Fixed
Girevole/Swivel
Inox/Stainless steel base



AL4
Girevole alluminio
swivel alu



Telaio 4 gambe verniciato
alluminio
4-legs frame alu painted

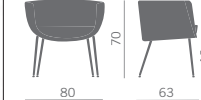

A richiesta
Omologazione al fuoco Classe 1IM



Poltroncina per zona attesa e riunione, su telaio in acciaio verniciato alluminio nelle versioni di rivestimento monocolor e bicolore.

Chair for waiting areas and conference rooms, with aluminium painted steel frame, available in monocolour or bicolor upholstery.

Chaise pour salles d'attentes et de réunions, avec châssis en acier gris aluminium epoxy verni, disponible dans les versions monocolor et bicolore.

Polstersessel für Besucher- oder Konferenzräume, auf Stahlgestell alusilber lackiert, mit ein- oder zweifarbiger Polsterung.

Silla para zona de espera y reunión, sobre estructura de acero pintado aluminio en las versiones de revestimientos mono o bicolore.



Bracciolo
Arm

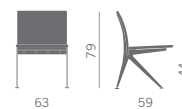

KBR5
Aggancio
Linking device

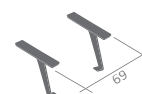

A richiesta
Omologazione al fuoco Classe 1IM

O4 KAYAK



Versioni con cucitura quadrettata/Squared stitching versions

Poltrona per zone relax, attesa e conversazione con varie soluzioni di basi fisse e girevoli

Armchair for relaxing, waiting and reception areas, with different options of either fixed or swivel bases.

Fauteuil pour zone relax, salles d'attente et de conversation, avec différentes solutions de piétements fixes et pivotants.

Sessel geeignet für Relaxzone, Empfangs- und Besprechungsräume, mit verschiedenen drehbaren und feststehenden Gestellen.

Sillón para zonas de relax, espera y conversación, con diferentes soluciones de estructuras fijas y bases giratorias.



Girevole o fissa cromata
Swivel or fixed chromed



Telaio cromato fisso
Fixed chromed frame

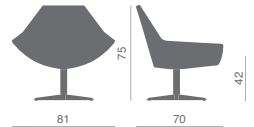

AL4
Girevole alluminio
swivel alu



Monocolore
One colour



Fissa/Fixed
Girevole/Swivel
Inox/Stainless steel
base



Bicolore
Two colours

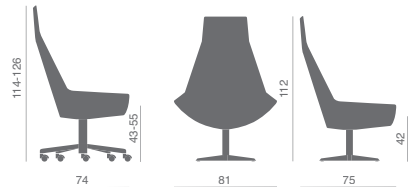

A richiesta
Omologazione al fuoco Classe 1IM

O4 KROKUS



Poltrona per zone attesa e conversazione nelle versioni:

- Base cromata a 4-razze in acciaio cromato o alluminio
- Base rotonda in acciaio inox
- Rivestimento monocolore - Rivestimento bicolore

Lounge chair for waiting or drawing-room, with the following options:

- 4-stars frame in chromed or aluminium painted steel
- Round stainless steel base
- Single color upholstery - Two-colors upholstery

Chaise pour salle d'attente ou conversation dans les versions:

- piétement à 4-branches en acier chromé ou aluminium
- piétement ronde en acier inox
- revêtement uni - revêtement 2 coloris

Polstersessel ideal für Warte u. Gesprächsräume, erhältlich in den folgenden Ausführungen:

- 4-Fußkreuz, verchromt oder Aluminium
- Bodenteller aus Edelstahl
- Bezug: einfarbig - Bezug: zweifarbig

Sillón para áreas de espera y descanso en las versiones:

- Base cromada a 4-radios o aluminio
- Base redonda en acero inoxidable
- Tapizado mono-color - Tapizado bi-color.



Bicolore
Two colours



Monocolore
One colour



Girevole o fissa cromata
Swivel or fixed chromed

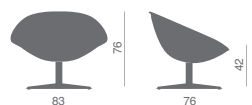

Fissa/Fixed
Girevole/Swivel
Inox/Stainless steel base

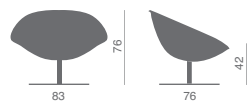

AL4
Girevole alluminio
swivel alu

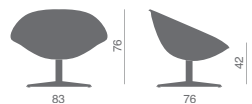

A richiesta
Omologazione al fuoco Classe 1IM

O4 KOCCOLA



Poltrona per zone attesa, conversazione, riunione nelle versioni monocolore e bicolore, con piedini o ruote.

Armchair for waiting, conversation and meeting areas available in one-colour and two-colours, with feet or castors.

Fauteuil pour salles d'attente, de conversation et réunion, disponible dans la version mono-couleur et bi-couleurs, sur patins ou roulettes.

Sessel ideal für Warte u. Besprechungsräume, einfarbig und zweifarbig, mit Gleitern oder Rollen

Sillón para áreas de espera, conversación y reunión, tapizado mono-color o bicolor, con topes o ruedas.



c/ruote
W/castors



Monocolore
One colour



c/piedini
W/feet



Bicolore
Two colours

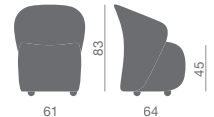

A richiesta
Omologazione al fuoco Classe 1IM

O4 KOCCOLA PLUS



Poltrona con schienale alto per zone attesa, relax, conversazione nelle versioni monocolore o bicolore, con piedini.

Armchair with high back for waiting, relax and conversation areas, available in one-colour or two-colours versions, with feet.

Fauteuil avec haut dossier pour zone relax, salle d'attente et de conversation, disponible dans les versions mono-couleur ou bi-couleurs, sur patins.

Sessel mit höher Rückenlehne für Relaxzone, Empfangs- und Gesprächsräume, in den Ausführungen einfarbig oder zweifarbig, mit Gleitern.

Sillón respaldo alto para zonas de relax, espera y conversación, mono-color o bicolor, con topes.



c/piedini
W/feet



Appoggiatesta
Headrest



Monocolore
One colour



Bicolore
Two colours

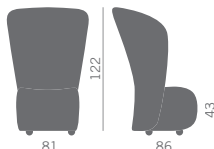

A richiesta
Omologazione al fuoco Classe 1IM

O4 KOCCOLA TOP (IMBOTTITURA "ROMBOIDALE"/ "RHOMBOIDAL" PAD)



Poltrona con schienale alto per zone attesa, relax, conversazione nelle versioni monocolore o bicolore, con piedini.

Armchair with high back for waiting, relax and conversation areas, available in one-colour or two-colours versions, with feet.

Fauteuil avec haut dossier pour zone relax, salle d'attente et de conversation, disponible dans les versions mono-couleur ou bi-couleurs, sur patins.

Sessel mit höher Rückenlehne für Relaxzone, Empfangs- und Gesprächsräume, in den Ausführungen einfarbig oder zweifarbig, mit Gleitern.

Sillón respaldo alto para zonas de relax, espera y conversación, mono-color o bicolor, con topes.



Appoggiatesta
Headrest



Monocolore
One colour



Bicolore
Two colours

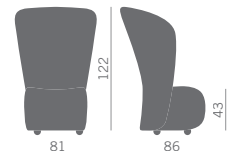

A richiesta
Omologazione al fuoco Classe 1IM

O4 KENSHO (POUF)



Serie di pouf di forma triangolare arrotondata

- 3 dimensioni
- Con piedini o ruote
- Monocolore o bicolore

Range of round edged triangle pouf

- 3 dimensions
- With castors or feet
- One color or two colors upholstery

Gamme de pouf en forme de triangle arrondi

- 3 dimensions
- Avec patins ou roulettes
- Revêtement unicolore ou deux couleurs

Serie von Hocker dreieckig mit gebogenen Kanten

- 3 verschiedene Größen
- Mit Rollen oder Gleitern
- Einfarbig oder zweifarbig

Serie de pouff de forma triangular redondeada

- 3 dimensiones
- Con topes o ruedas
- Mono-color o bi-color

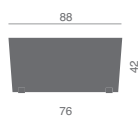
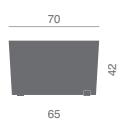
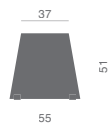

Monocolore
One colour



Bicolore
Two colours



A richiesta
Omologazione al fuoco Classe 1IM

O4 KUBOX



Pouf per zona attesa nelle versioni:

- 1-2-3 posti
- con 4 piedini
- con 4 ruote.

Pouf for waiting area available in the following versions:

- 1-2-3 places
- with 4 feet
- with 4 castors

Pouf pour salles attente:

- à 1-2-3 places
- avec 4 patins
- avec 4 roulettes

Hocker für Wartebereich, erhältlich in den folgenden Ausführungen:

- 1-2-3 Sitze
- mit 4 Gleitern
- mit 4 Rollen

Pouf para zonas de espera en las versiones:

- 1-2-3 plazas
- con 4 topes
- con 4 ruedas

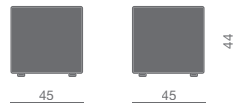

Particolare cuciture
Stitching detail



A richiesta
Omologazione al fuoco Classe 1IM

O4 KROFF



Pouf per zona attesa nelle versioni:

- con 4 piedini
- con 4 ruote
- rivestimento monocolore
- rivestimento bicolore.

Pouf for waiting area available in the following versions:

- with 4 feet
- with 4 castors
- single color upholstery
- two-colors upholstery

Pouf pour salles attente:

- avec 4 patins
- avec 4 roulettes
- revêtement uni
- revêtement 2 coloris

Hocker für Wartebereich, erhältlich in den folgenden Ausführungen:

- mit 4 Gleitern
- mit 4 Rollen
- Bezug: einfarbig
- Bezug: zweifarbig

Pouf para zonas de espera en las versiones:

- con 4 topes
- con 4 ruedas
- tapizado mono-color
- tapizado bi-color.



Versione monocolore
One colour version



Versione bicolore
Two colours version

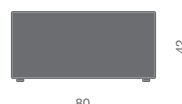

A richiesta
Omologazione al fuoco Classe 1IM

O4 KIMERA (ATTESA-WAITING)



Imbottitura "romboidale" - "Rhomboidal" pad

Poltrona per zone relax, attesa e conversazione con varie soluzioni di basi fisse e girevoli

Armchair for relaxing, waiting and reception areas, with different options of either fixed or swivel bases.

Fauteuil pour zone relax, salles d'attente et de conversation, avec différentes solutions de piétements fixes et pivotants.

Sessel geeignet für Relaxzone, Empfangs- und Besprechungsräume, mit verschiedenen drehbaren und feststehenden Gestellen.

Sillón para zonas de relax, espera y conversación, con diferentes soluciones de estructuras fijas y bases giratorias.



Girevole o fissa cromata
Swivel or fixed chromed



AL4
Girevole alluminio
swivel alu



Fissa/Fixed
Girevole/Swivel
Inox/Stainless steel base

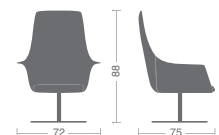
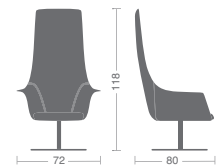

A richiesta
Omologazione al fuoco Classe 1IM

O4 KOSA



Poltroncina per riunione o zona attesa nelle versioni monocolor o bicolor realizzati con struttura d'acciaio e resine poliuretatiche autoestinguenti.

Armchair for meeting and waiting areas available in one-color and two-colors versions. The structure is in steel filled with self-extinguishing polyurethane resins.

Fauteuil pour salles d'attente et réunion disponibles dans les versions monocolor et bicolor. La structure est en acier et résins polyuréthane non-feu.

Sessel in zwei Varianten - einfarbig und zweifarbig - ideal fuer Ihren Empfang und Konferenzraum. Die Schalenbauweise ist aus Stahl und feuerhemmenden Polyurethanharzen.

Butaca para reunión o espera en las versiones mono o bicolor realizados sobre estructura de acero relleno con resinas de poliuretano ignifugas.

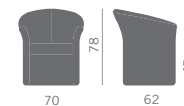

A richiesta
Omologazione al fuoco Classe 1IM

H O4 KONDOR



Sistema di confortevoli sedute per l'attesa e reception, composto da elementi a 1 e 2 posti, componibili e aggregabili tra loro.

This line of comfortable seating with modular or joinable 1-seater and 2-seater units is perfect for waiting and reception areas.

Système d'attente confortable composé d'éléments 1 et 2 places qui se juxtaposent ou s'accrochent, idéal pour équiper tous les espaces d'attente et de réception.

Diese bequeme Sitzgarnitur, die aus zusammensetzbaren und verkettbaren 1- und 2-Sitzer Elementen besteht, ist ideal um einen Empfang oder Warteraum einzurichten.

Sistema de confortables butacas para espera y recepción, está compuesto por elementos a 1 o 2 plazas componibles y unidos entre ellos.



Particolare schienale
Backrest detail



Versioni piede alluminio
Aluminium leg versions



Versione con braccioli verniciati alluminio
Version with alu painted arms

 A richiesta
Omologazione
al fuoco Classe 1IM

H O4 KUROS 90



Sistema composto da una serie di elementi che, diversamente combinati, danno soluzioni estetiche e funzionali adatte a qualsiasi tipo di necessità.

Modular seating system that can be combined together to meet any environment requirement.

Système d'assises créé par une série d'éléments qui peuvent être montés dans différentes combinaisons, permettant de satisfaire toute nécessité.

System, das aus einer Reihe von Elementen besteht, die verschiedenartig miteinander kombiniert werden können und somit jeglichen ästhetischen und funktionellen Anforderungen gerecht werden.

Sistema caracterizado por una serie de elementos que, puestos en diferentes maneras, ofrecen soluciones estéticas y funcionales que se pueden adaptar a cualquier tipo de necesidad.

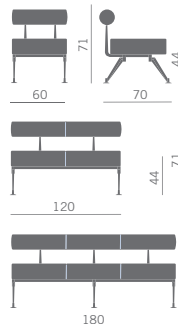

Particolare schienale
Backrest detail

 A richiesta
Omologazione al fuoco Classe 1IM



Programma componibile per spazi attesa, conversazione, incontri. E' formato da vari moduli per soluzioni angolari o lineari nelle versioni di rivestimento mono o bicolore.

Modular range for waiting, conversation and meeting areas made of various interchangeable units for corner or linear solutions in one-color or bi-color upholstery versions.

Système modulaire pour salles d'attente, de conversation et de rencontre composé de différents éléments pour solutions angulaires ou linéaires, disponible dans les versions de revêtement mono-couleur ou bi-couleur.

Zusammensetzbare Polstergruppe, ideal für Empfangs- und Warteräume sowie für Meeting, bestehend aus verschiedenen Elementen für Eck- oder Linearlösungen, Ausführung ein- oder zweifarbig.

Programa componible para espacios de espera, conversación y reunión. Está compuesto por varios módulos para soluciones angulares o lineares en las versiones de revestimiento mono o bicolore.

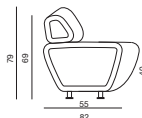
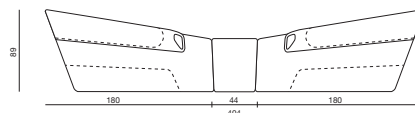
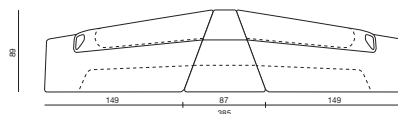
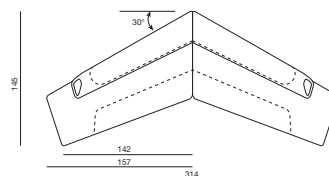
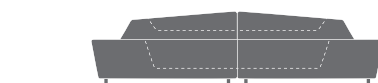

....M
Monocolore
One colour



....B
Bicolore
Two colours



....L
Monocolore con parti laterali
in diverso colore
One colour with side parts
in a different colour



Particolare fianco
Side detail



Elemento destro
Right element



Elemento sinistro
Left element



Elemento angolare
Corner element



Seduta collegamento
Linking seat

Soluzione di componibilità - Modular solution



A richiesta
Omologazione al fuoco Classe 1IM



Poltrona per zone attese, conversazione e incontro, formata da modulo intercambiabile, componibile ed agganciabile.

Armchair suitable for waiting rooms, receptions or meeting areas consisting of interchangeable modular units.

Fauteuil pour salles d'attente, de rencontre et de conversation composé d'un élément interchangeable et crochetable.

Polstersessel ideal für Empfang und Warteraum besteht aus einzigen austauschbaren Element, verkettbar und zusammensetzbar.

Sillón para áreas de espera, conversación y reunión, compuesto por un módulo intercambiable, componible y enganchable.

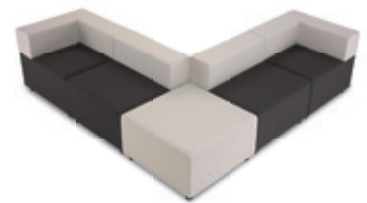
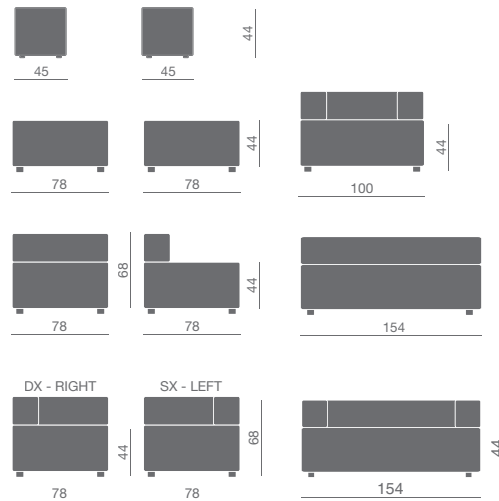

Versione sedile senza "cuciture"
Seat without "stitching" version



A richiesta
Omologazione al fuoco Classe 1M

O4 KUADRA SEDILE/SEAT "CUCITURA QUADRETTATA"/"SQUARED STITCHING"



Poltrona per zone attese, conversazione e incontro, formata da modulo intercambiabile, componibile ed agganciabile.

Armchair suitable for waiting rooms, receptions or meeting areas consisting of interchangeable modular units.

Fauteuil pour salles d'attente, de rencontre et de conversation composé d'un élément interchangeable et crochetable.

Polstersessel ideal für Empfang und Warteraum besteht aus einzigen austauschbaren Element, verkettbar und zusammensetzbar.

Sillón para áreas de espera, conversación y reunión, compuesto por un módulo intercambiable, componible y enganchable.

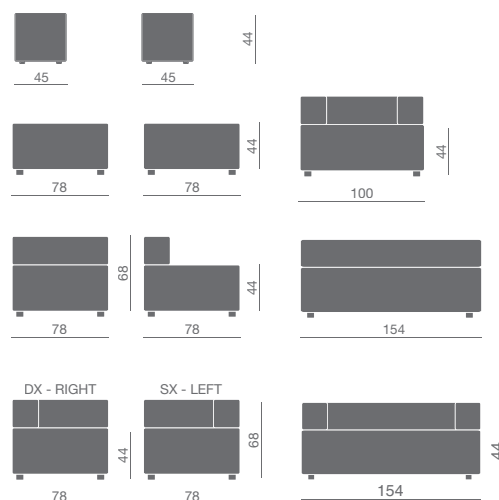

Versione sedile con "cucitura quadrettata"
Seat with "squared stitching" version



A richiesta
Omologazione al fuoco Classe 1M

O4 KUADRA TOP



Poltrona per zone attesa, conversazione e incontro, formata da modulo intercambiabile, componibile ed agganciabile.

Armchair suitable for waiting rooms, receptions or meeting areas consisting of interchangeable modular unit.

Fauteuil pour salles d'attente, de rencontre et de conversation composé d'un élément interchangeable et crochetable.

Polstersessel ideal für Empfang und Warteraum besteht aus einzigen austauschbaren Element, verkettbar und zusammensetzbar.

Sillón para áreas de espera, conversación y reunión, compuesto por un módulo intercambiable, componible y enganchable.



A richiesta
Omologazione al fuoco Classe 1IM

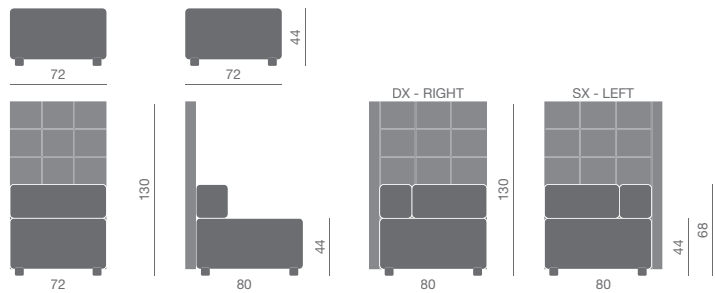

O4 KLUB



Serie formata da poltrona e divano a 2 e 3 posti per zone attesa e conversazione.

Range consisting of armchair, 2-seater sofa, 3-seater sofa, particularly suitable for waiting and conversation rooms.

Série composée de chauffeuse et canapés à 2 et 3 places, très indiqué pour salles d'attente et de conversation.

Die Serie besteht aus 3-Sitzer Sofa, 2-Sitzer Sofa und Sessel, besonders geeignet für Warten- und Gesprächsräume.

Programa de sofá a 3 plazas, a 2 plazas y butaca para zonas de espera y recreo.

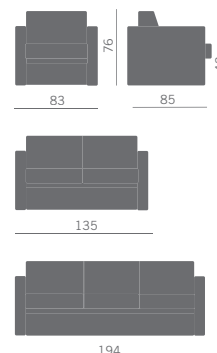

O4 KORALL



Poltrona, divano 2 posti e divano 3 posti per la zona attesa e conversazione.

Armchair, 2-seater sofa and 3-seater sofa for reception and waiting areas.

Programme attente composé par chauffeuse, canapé 2 places et canapé 3 places.

Sitzprogramm für den Empfang, der aus Sessel, 2-Sitzer Sofa und 3-Sitzer Sofa besteht.

Butaca, sofá a 2 plazas y sofá a 3 plazas para zonas de espera y recreo.



Versione con piede cromato
Version with chromed feet



Versione con telaio verniciato alluminio
Version with alu painted frame



KL31
Versione fissa con 4 razze cromate
Version with chromed fixed 4 stars steel base

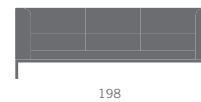
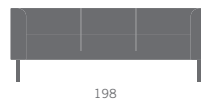
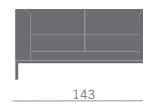
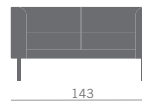
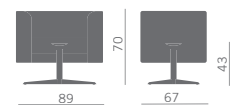
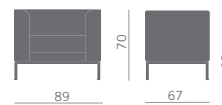
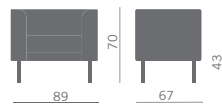

 A richiesta
Omologazione al fuoco Classe 1IM

O4 KOMODO



Poltrona e divano a 2 e 3 posti su telaio portante in acciaio verniciato alluminio.

Armchair and sofa with 2 and 3 seats with supporting frame in painted aluminium steel.

Chauffeuse et sofa à 2 et 3 places sur châssis portant en acier verni aluminium.

Sessel und 2-3-Sitzer Sofa mit Trägergestell aus Stahl alufarbe lackiert.

Butaca, sofá de 2 y 3 plazas sobre estructura en acero pintado aluminio.

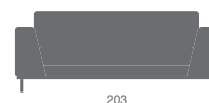
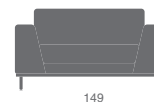
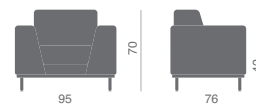

Versione con telaio verniciato alluminio
Version with painted alu. frame

 A richiesta
Omologazione al fuoco Classe 1IM

O4 KURSAL



Poltrona e divano 2-3 posti per zone attesa e conversazione su una struttura portante in acciaio verniciato colore alluminio satinato.

Armchair and 2-3-seater sofa for waiting and conversation areas with external steel structure, epoxy finish in satinized aluminium colour.

Chaise longue et canapé 2-3 places pour salles d'attente et de conversation supportés par une structure en acier, époxy en aluminium satiné.

Sessel und 2-3-Sitzer Sofa für Empfangs- und Besprechungsräume mit tragendem Gestell aus Stahl, satiniert Aluminium lackiert.

Butaca y sofá a 2-3 plazas para zonas de espera y conferencia sobre estructuras de acero pintadas color aluminio.

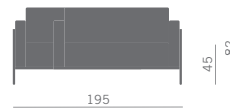
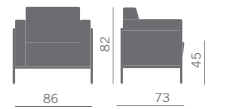

A richiesta
Omologazione al fuoco Classe 1IM



Versione con telaio verniciato alluminio
Version with alu painted frame

O4 KRISTALL



Poltrona e divano 2-3 posti con piedini in acciaio verniciati alluminio per zona attesa e conversazione.

Armchair and 2-3-seater sofa for lounge and conversation areas, equipped with painted aluminium steel feet.

Chaise longue et canapé à 2-3 places avec pieds en acier époxy aluminium pour salles d'attente et de conversation.

Sessel und 2-3-Sitzer Sofa mit Füßen aus Stahl, silbergrau lackiert, ideal für den Empfang und den Gesprächsraum.

Butaca y sofá a 2-3 plazas con pies en acero pintados aluminio para zonas de espera y recreo.

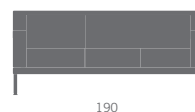
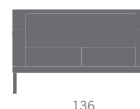

A richiesta
Omologazione al fuoco Classe 1IM



Versione con piede verniciato alluminio
Version with painted alu. feet

O4 KLASSE



Poltrona, divano 2 posti e divano 3 posti per la zona attesa e conversazione.

Armchair, 2-seater sofa and 3-seater sofa for reception and waiting areas.

Programme attente composé par chauffeuse, canapé 2 places et canapé 3 places.

Sitzprogramm für den Empfang, der aus Sessel, 2-Sitzer Sofa und 3-Sitzer Sofa besteht.

Butaca, sofá a 2 plazas y sofá a 3 plazas para zonas de espera y recreo.



Versione con telaio cromato
Version with chromed frame



Versione con telaio verniciato alluminio
Version with painted alu. frame



Versione con piede cromato
Version with chromed feet

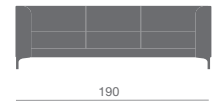
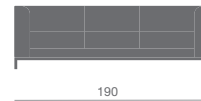
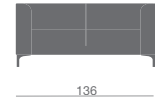
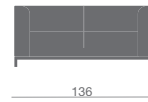
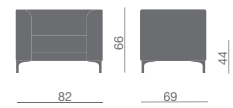
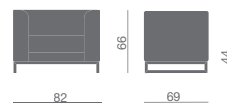

Versione monocolore
One colour version



Versione bicolore
Two colours version



A richiesta
Omologazione al fuoco Classe 1M

O4 KALYPSO



Poltrona, divano 2 posti e divano 3 posti per la zona attesa e conversazione, con piedi verniciati.

Armchair, 2-seater sofa and 3-seater sofa for reception and waiting areas available with painted feet.

Programme attente composé par chauffeuse, canapé 2 places et canapé 3 places disponibles avec pieds vernis.

Sitzprogramm für den Empfang, der aus Sessel, 2-Sitzer Sofa und 3-Sitzer Sofa besteht, erhältlich mit lackierten Füßen.

Butaca, sofá a 2 plazas y sofá a 3 plazas para espera y comunidad, con pies pintados en color aluminio.

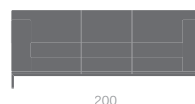
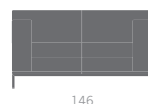
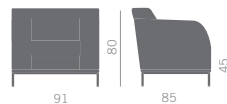

Versione con telaio verniciato alluminio
Version with alu painted frame



A richiesta
Omologazione al fuoco Classe 1M



Travi · tavoli

Benches, tables
Poutres, tables
Bänke, tische
Bancadas, mesas

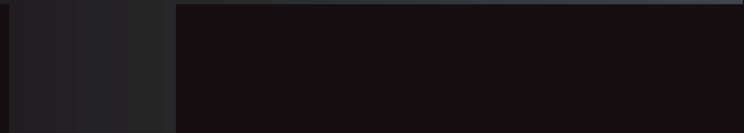
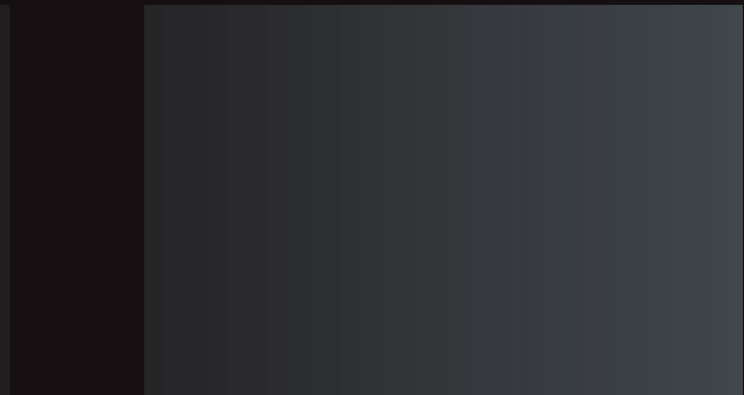



O4 KICCA



Seduta su trave a 2-3-4 posti

- Scocca in polipropilene vari colori
- Scocca in polipropilene vari colori con sedile imbottito
- Scocca in polipropilene vari colori con sedile e schienale imbottiti

Bench seating with 2-3-4 seats

- Polypropylene shell in various colors
- Polypropylene shell in various colors with padded seat
- Polypropylene shell in various colors with padded seat and back

Poutre à 2-3-4 places

- Coque en polypropylène en différents couleurs
- Coque en polypropylène en différents couleurs avec assise garnie
- Coque en polypropylène en différents couleurs avec assise et dossier garnis.

Sitzbank-System 2+3+4 sitzige

- Schale aus Polypropylen in verschiedenen Farben
- Schale aus Polypropylen in verschiedenen Farben und Sitz gepolstert
- Schale aus Polypropylen in verschiedenen Farben mit Sitz+Rücken gepolstert

Elemento para bancada de 2-3-4 plazas

- Carcasa en polipropileno varios colores
- Carcasa en polipropileno varios colores con asiento tapizado
- Carcasa en polipropileno varios colores con asiento y respaldo tapizados



A richiesta
Omologazione al fuoco Classe 1M



Piede vern. col. alluminio
Painted alu leg



Piede alluminio lucido
Polished alu. leg

Versioni polipropilene
Polypropylene versions

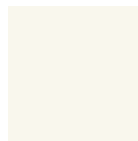

C
Crema (bianco)
Cream (White)
Crème (blanc)
Crème (Weiss)
Crema (bianco)



T
Tortora
Dove-colour
Tourterelle
Taube
Gris pardo



V
Verde
Green
Vert
Grün
Verde



B
Blu
Blue
Bleu
Blau
Azul



R
Rosso
Red
Rouge
Rot
Rojo



G
Grigio
Grey
Gris
Grau
Gris



A
Arancio
Orange
Orange
Orange
Naranja



N
Nero
Black
Noir
Schwarz
Negro



Sedile imbottito
Padded seat



Sedile-schienale imbottito
Padded seat-back

O4 KALEA



Seduta su trave a 2-3-4 posti

- scocca in polipropilene monocolor
- scocca in polipropilene bicolor
- scocca in polipropilene monocolor o bicolor con sedile imbottito

Bench seating with 2-3-4 seats

- one colour polypropylene shell
- two colours polypropylene shell
- one or two colours polypropylene shell with padded seat

Poutre à 2-3-4 places

- coque en polypropylène monocolor
- coque en polypropylène deux couleurs
- coque en polypropylène monocolor ou à deux couleurs avec assise rembourrée

Sitzbank-System 2+3+4 sitzige

- Schale aus Polypropylene einfarbig
- Schale aus Polypropylene zweifarbig
- Schale aus Polypropylene ein- oder zweifarbig mit Sitz gepolstert

Elemento para bancada de 2-3-4 plazas

- carcasa en polipropileno mono-color
- carcasa en polipropileno bi-color
- carcasa en polipropileno mono-color o bi-color con asiento tapizado



A richiesta
Omologazione al fuoco Classe 1M



Bracciali all. lucido
Polished alu. arms



Piede alluminio lucido
Polished alu. leg

Polipropilene monocolor
One colour polypropylene



Polipropilene bicolor
Two colours polypropylene



Polipropilene mono/bicolor sedile imbottito
One/Two colours polypropylene Padded seat



Retroschienale lucido / Glossy backshell



C
Crema (bianco)
Cream (White)

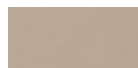

T
Tortora
Dove-colour



V
Verde
Green



R
Rosso
Red



A
Arancio
Orange



B
Blu
Blue



G
Grigio
Grey



N
Nero
Black



CT
Crema/Tortora
Cream/Dove-colour



CV
Crema/Verde
Cream/Green



CR
Crema/Rosso
Cream/Red



CA
Crema/Arancio
Cream/Orange



CB
Crema/Blu
Cream/Blue



CG
Crema/Grigio
Cream/Grey



CN
Crema/Nero
Cream/Black

O4 KRIZIA



Seduta su trave a 2-3-4 posti

- Scocca in polycarbonato vari colori
- Scocca in polycarbonato con sedile rivestito
- Scocca in polycarbonato con sedile e schienale rivestiti

Bench seating with 2-3-4 seats

- Polycarbonate shell in various colors.
- Polycarbonate shell in various colors with padded seat
- Polycarbonate shell in various colors with padded seat and back

Poutre à 2-3-4 places

- Coque en polycarbonate en différents couleurs
- Coque en polycarbonate en différents couleurs avec assise garnie
- Coque en polycarbonate en différents couleurs avec assise et dossier garnis

Sitzbank-System 2-3-4 sitzige

- Schale aus Polycarbonat in verschiedenen Farben
- Schale aus Polycarbonat in verschiedenen Farben mit Sitz gepolstert
- Schale aus Polycarbonat in verschiedenen Farben mit Sitz+Rücken gepolstert

Elemento para bancada de 2-3-4 plazas

- Carcasa en polycarbonato varios colores
- Carcasa en polycarbonato varios colores con asiento tapizado
- Carcasa en polycarbonato varios colores con asiento y respaldo tapizados



Piede vern. color alluminio
Alu painted leg



Piede alluminio lucido
Polished alu. leg

Polycarbonato - Polycarbonate



Bianco
White
Blanc
Weiss
Blanco



Rosso
Red
Rouge
Rot
Rojo



Moka



Nero
Black
Noir
Schwarz
Negro



Trasparente
Transparent
Transparent
Transparent



Sedile imbottito
Padded seat



Sedile/schienale imbottiti
Padded seat/back

O4 KIMBOX



Seduta su trave a 2-3-4 posti

- Scocca rovere naturale
- Scocca con sedile imbottito
- Scocca con sedile e schienale imbottiti

Bench seating with 2-3-4 seats

- Natural oak wood shell
- Shell with padded seat
- Shell with padded seat and back

Poutre à 2-3-4 places

- Coque en multiplis de chêne naturel
- Coque avec assise garnie
- Coque avec assise et dossier garnis

Sitzbank-System 2+3+4 sitzige

- Schale aus Eichenholz natur lackiert
- Schale mit Sitz gepolstert
- Schale mit Sitz+Rücken gepolstert

Elemento para bancada de 2-3-4 plazas

- Carcasa en roble natural
- Carcasa con asiento tapizado
- Carcasa con asiento y respaldo tapizados

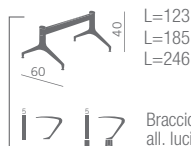

Braccioli all. lucido
Polished alu. arms



Piede vern. col. alluminio
Alu painted leg



Piede alluminio lucido
Polished alu. leg



Rovere naturale
Natural oak wood



Sedile imbottito
Padded seat



Sedile/schienale imbottiti
Padded seat/back



A richiesta
Omologazione al fuoco Classe 11M
(con sedile o sedile/schienale imbottiti)

O4 KRUNA (BENCH-MESH-PLUS)



Seduta su trave a 2-3-4 posti

- Struttura unica portante in acciaio cromato
- Sedile e schienale in rete poliestere vari colori
- Sedile e schienale rivestito in vari colori e soluzioni

Bench seating with 2-3-4 seats

- Sole supporting frame in chromed steel
- Seat and back in various colors of polyester mesh
- Seat and back upholstered in various colors and versions

Poutre à 2-3-4 places

- Structure unique de support en acier chromé
- Assise et dossier en résille polyester de différents couleurs
- Assise et dossier revêtus en différentes nuances et versions.

Sitzbank-System 2-3-4 sitzige Module

- Tragende Struktur aus Stahl verchromt
- Sitz+Rücken mit Netzbespannung aus Polyester in verschiedenen Farben
- Sitz+Rücken gepolstert in verschiedenen Farben und Ausführungen

Elemento para bancada de 2-3-4 plazas

- Estructura única de soporte en acero cromado
- Asiento y respaldo en malla poliéster varios colores
- Asiento y respaldo tapizado en varios colores y soluciones

Kruna (mesh) (sedile/schiena rete - Mesh seat/backrest)



Kruna plus (linear)

L
Imbottitura "lineare"
"Linear" pad



Kruna plus (rhomboidal)

R
Imbottitura "romboidale"
"Rhomboidal" pad

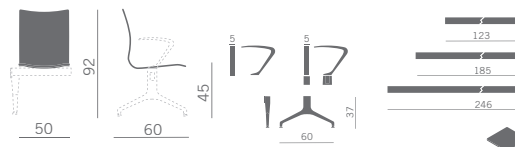

O4 KONTUR



Seduta su trave a 2-3-4 posti

- Sedile imbottito e schienale in lamiera traforata
- Sedile e schienali imbottiti

Bench seating with 2-3-4 seats

- Perforated steel frame painted aluminium with padded seat
- Perforated steel frame painted aluminium with padded seat and back.

Poutre à 2-3-4 places

- Tôle percée vernie aluminium avec assise garnie
- Tôle percée vernie aluminium avec assise et dossier garnis

Sitzbank-System 2-3-4 sitzige Module

- Sitz gepolstert, Rücken aus Lochblech
- Sitz+Rücken gepolstert

Elemento para bancada de 2-3-4 plazas

- Asiento tapizado respaldo en chapa perforada
- Asiento y respaldo tapizados

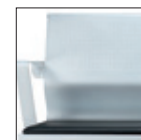
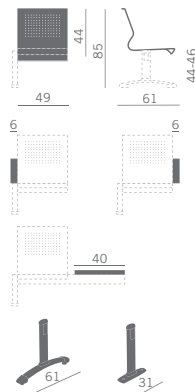

Sedile imbottito e schienale in lamiera traforata
Padded seat and backrest in perforated plate



Sedile e schienale imbottiti
Padded seat and backrest



Telaio verniciato alluminio
Painted alu. frame

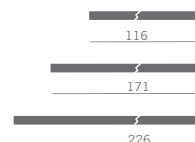

O4 KARGO

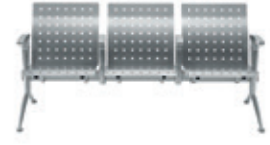
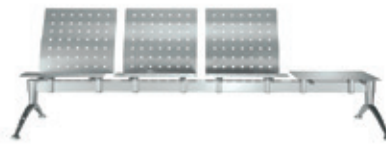

Sistema di sedute su trave a 2-3-4 posti per grandi spazi attesa.

Bench seating system for waiting areas, available with two, three or four seat units.

Système d'assises sur poutre à 2-3-4 places destiné aux grands espaces d'attente.

Sitzbank-System für weitläufige Wartebereiche; 2-3-4-sitzigen Module.

Sistema de sillas en bancada a 2-3-4 plazas para amplios espacios de espera.

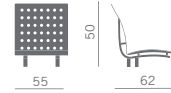

KRG10
Sedile/schienale lamiera perforata
Seat backrest perforated plate

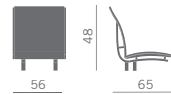
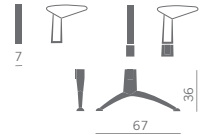

KRG20
Sedile/schienale poliuretano integrale grigio antracite
Seat backrest antracite grey polyurethane

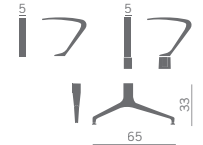

A richiesta
Omologazione al fuoco Classe 1M

Piede alluminio lucido
Polished aluminium leg



Piede verniciato alluminio
Aluminium painted frame

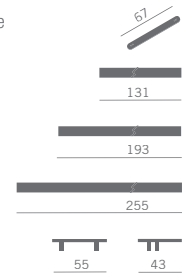

O4 KORNER



Sistema di sedute per grandi spazi attesa su trave in acciaio verniciato, realizzate in:

- lamiera traforata e verniciata
- sedile imbottito e schienale in lamiera traforata
- sedile e schienale imbottiti.

Bench seating system, in painted steel, for big waiting areas, available in the following versions:

- in perforated and painted plate
- with padded seat and backrest in perforated plate
- with padded seat and backrest.

Système d'assises sur poutre en acier verni, destiné aux grands espaces d'attente, réalisé:

- en tôle percée et vernie
- avec assise rembourrée et dossier en tôle percée
- avec assise et dossier rembourrés.

Sitzbank-System für großräumige Wartebereiche, mit Traverse aus lackiertem Stahl, lieferbar in folgenden Ausführungen:

- aus lackiertem Lochblech
- mit gepolstertem Sitz, Rückenlehne aus Lochblech
- mit gepolsterten Sitz und Rückenlehne.

Programa de espera, estudiado para anchos espacios, sobre barra en acero pintado, realizadas en:

- Chapa perforada y pintada
- Asiento embutido y respaldo en chapa perforada
- Asiento y respaldo embutidos.

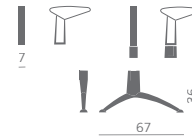
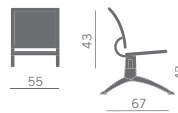

Sedile/schienale lamiera traforata e verniciata
Seat/backrest perforated and painted plate

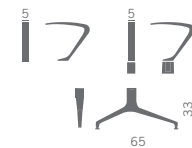
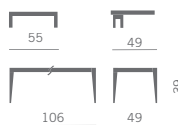
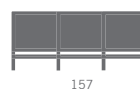
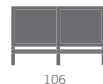

Sedile imbottito e schienale in lamiera traforata
Padded seat and backrest in perforated plate



A richiesta
Omologazione al fuoco Classe 1M

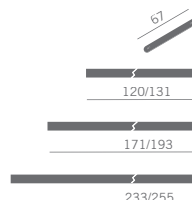

Sedile e schienale imbottiti
Padded seat and backrest

O4 KADENZA (SEDILE/SEAT TIP-UP)



Poltrona per sale riunioni o conferenza su trave con sedile ribaltabile. Disponibile nelle versioni con braccioli e tavoletta scrittoio a scomparsa.

Series of bench seatings for meeting and conference rooms with tip-up seat available in the following versions with armrests and foldaway writing tablet.

Séries d'assises sur poutre avec assise rabattable pour salles de réunions et de conférences disponible dans les versions suivantes avec accoudoirs et tablette étroite à disparition.

Sessel geeignet für Versammlungs- oder Konferenzräume auf Traverse mit Klappsitz. Verfügbar in den Ausführungen mit Armlehnen und versenkbarem Schreibbrett.

Butaca para sala reunión o conferencia sobre barra metálica con asiento abatible. Disponible en las versiones con brazos y pala escritorio a desaparición.

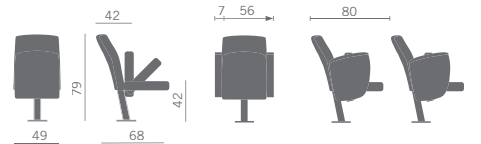

Piede fissaggio a pavimento
Leg to be fixed on the floor

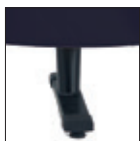

Piede libero
Free standing leg



Con tavoletta antipanico
With antipanic writing tablet



Con tavoletta antipanico a scomparsa
With foldaway antipanic writing tablet

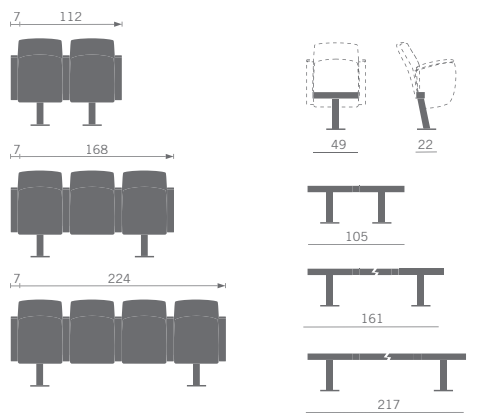

KZ35
Giunzione per trave
Joint element for beam



Poltrona per sale riunioni o conferenza completamente smontabile, disponibile nelle versioni:

- schienale alto o basso;
- bracciolo con possibilità di tavoletta scrittoio antipanico a scomparsa.

Armchair for meeting and conference areas that can be completely disassembled, available in the versions:

- high or low backrest;
- armrest with antipanic foldaway writing tablet.

Fauteuil pour salles réunion ou conférence complètement démontable, disponible dans les versions:

- dossier haut ou bas;
- accoudoir avec tablette écrivain antipanique à disparition.

Sessel für Gesprächs- oder Konferenzräume komplett abmontierbar, in den folgenden Ausführungen erhältlich:

- Rücken hoch oder niedrig;
- Armlehne mit versenkbarer antipanic Schreibplatte.

Butaca para salas reuniones o conferencia completamente desmontable, disponible en las versiones:

- respaldo alto o bajo
- brazos con posibilidad de pala escritorio antipánico y escamoteable

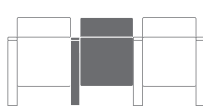
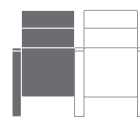
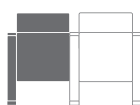
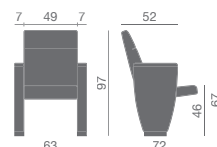
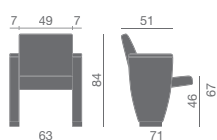



Serie di tavoli di forma triangolare arrotondata.

- Piano in acciaio spessore 4 mm. verniciato: bianco - giallo - arancio - tortora - lava
- Basi a 3 piedi in tondino d'acciaio, verniciate : bianco - giallo - arancio - tortora - lava
- Basi tonde piane in acciaio verniciato nei colori: bianco - giallo - arancio - tortora - lava o cromate.

Range of round edged triangle tables.

- Steel top thickness 4mm. white - yellow - orange - dove-colour - lava painted.
- Rod steel frame with 3-supporting legs white - yellow - orange - dove-colour - lava painted.
- Round flat steel base white - yellow - orange - dove-colour - lava painted or chromed.

Gamme de tables en forme de triangle arrondi.

- Plateau en acier épaisseur 4 mm. verni : blanc - jaune - orange - tourterelle - lave
- Piétement à 3-branches en toron d'acier verni : blanc - jaune - orange - tourterelle - lave
- Piétement rond à plat en acier verni : blanc - jaune - orange - tourterelle - lave ou chromé.

Serie von Tischen dreieckig mit gebogenen Kanten.

- Platte aus Stahl lackiert, Stärke 4 mm in den Farben: weiß - gelb - orange - taube - lava
- Fußgestell aus drei Rundstahlstäben lackiert in den Farben: weiß - gelb - orange - taube - lava
- Gestell auf Säule mit flachem Bodenteller aus Stahl verchromt oder lackiert in den Farben: weiß - gelb - orange - taube - lava

Serie de mesas de forma triangular redondeada.

- Encimera en acero pintado espesor 4mm: blanco - amarillo - naranja - arena - lava
- Bases en varilla de acero pintado en los colores: blanco - amarillo - naranja - arena - lava
- Bases redondas planas en acero pintado en los colores: blanco - amarillo - naranja - arena - lava, cromadas.

Basi in tondino Rod steel bases

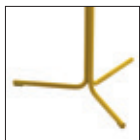

Bianco/White
Giallo/Yellow
Arancio/Orange
Tortora/Dove-colour
Lava

Piani tavolo Table tops



Bianco
White

Basi tonde Round bases



Bianco/White
Giallo/Yellow
Arancio/Orange
Tortora/Dove-colour
Lava



Giallo
Yellow



Tortora
Dove-colour



Cromata
Chromed



Arancio
Orange



Lava

PIANI TAVOLO - TABLE TOPS

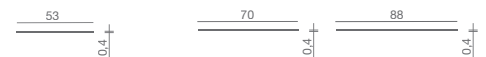

BASI IN TONDINO - ROD STEEL BASES



BASI TONDE - ROUND BASES

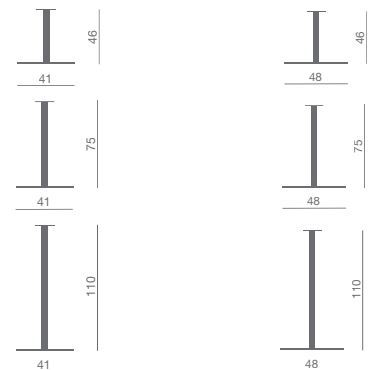



Serie di tavoli di forma tonda o quadrata.

- Piano in acciaio spessore 4 mm. verniciato: bianco - tortora - lava
- Basi tonde piane in acciaio verniciato nei colori: bianco - tortora - lava o cromate.

Range of round or squared shaped tables.

- Steel top thickness 4mm. white - dove-colour - lava painted.
- Round flat steel base white - dove-colour - lava painted or chromed.

Gamme des tables en forme ronde ou carré.

- Plateau en acier épaisseur 4 mm. verni : blanc - tourterelle - lave
- Piètement ronde à plat en acier verni : blanc - tourterelle - lave ou chromé.

Serie von Tischen rund oder quadratisch.

- Platte aus Stahl lackiert, Stärke 4 mm in den Farben: weiß - taube - lava
- Gestell auf Säule mit flachem Bodenteller aus Stahl verchromt oder lackiert in den Farben: weiß - taube - lava

Serie de mesas con forma redonda o cuadrada.

- Encimera en acero pintado espesor 4mm: blanco - arena - lava
- Bases redondas planas en acero pintado en los colores: blanco - arena - lava, cromadas.

PIANI TAVOLO - TABLE TOPS



BASI IN TONDINO - ROD STEEL BASES

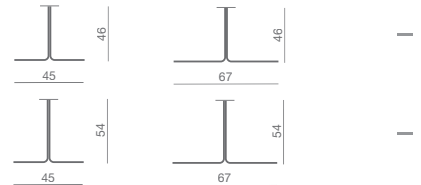

BASI TONDE - ROUND BASES

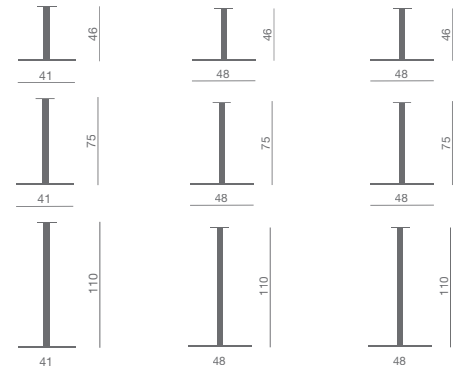

Basi in tondino Rod steel bases

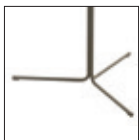

Bianco/White
Tortora/Dove-colour
Lava

Piani tavolo Table tops



Bianco/White
Tortora/Dove-colour
Lava
d. 60

Basi tonde Round bases



Bianco/White
Tortora/Dove-colour
Lava



Bianco/White
Tortora/Dove-colour
Lava
d. 80



Cromata
Chromed



Bianco/White
Tortora/Dove-colour
Lava
l. 70



Serie di tavoli caratterizzati da:

- due misure di altezza;
- piani tondi o quadrati in HPL compact laminato bianco (High Pressure Laminate) sp. 12 mm;
- basi tonde o quadre in acciaio verniciato bianco opaco o in acciaio inox satinato.

Series of tables available with:

- two heights;
- round or square tops in white HPL (High Pressure Laminate), thickness 12 mm;
- round or square bases in mat white painted steel or in satin stainless steel.

Gamme de tables caractérisés par:

- deux variantes d'hauteur
- plateaux ronds ou carrés en matériel lamifié HPL (lamifié à haute pression) blanc, épaisseur 12 mm;
- piétements ronds ou carrés en acier verni blanc opaque ou en acier inox satiné.

Serie von Tischen bestehend aus:

- Zwei Größen;
- Platte rund oder quadratisch aus HPL (High Pressure Laminate) weiß, Stärke 12 mm;
- Gestelle rund oder quadratisch aus Stahl matt weiß lackiert oder aus Edelstahl satiniert

Serie de mesas caracterizadas por:

- dos medidas de altura
- encimera redonda o cuadrada en laminado HPL blanco espesor 12 mm
- base redonda o cuadrada en acero pintado blanco opaco o en acero inox satinado



Piano tondo in HPL d.60 (bordo inclinato)
HPL round top d.60 (inclined side)



Piano quadrato in HPL l.60 (bordo inclinato)
HPL squared top w.60 (inclined side)

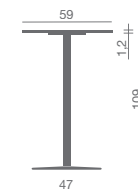
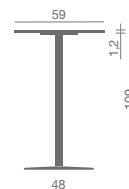
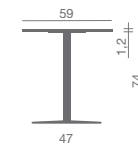
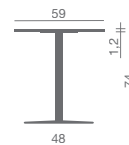

Piano tondo in HPL d.80 (bordo inclinato)
HPL round top d.80 (inclined side)



Piano quadrato in HPL l.80 (bordo inclinato)
HPL squared top w.80 (inclined side)

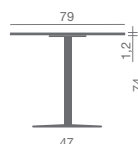
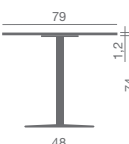

...TB
Base tonda in acciaio verniciato bianco
Round white painted steel base



...QB
Base quadrata in acciaio verniciato bianco
Square white painted steel base



...TS
Base tonda in acciaio inox satinato
Round satin stainless steel base



...QS
Base quadrata in acciaio inox satinato
Square satin stainless steel base



Particolare piano in HPL
HPL top detail



KKK6TB



KKK8TB



KKK6QB



KKK8QB



KKK6T4



KKK8T4



KKK6TS



KKK8TS



KKK6QS



KKK8QS



KKK6Q4



KKK8Q4

Piani HPL - HPL tops



KKK7BX



KKK7NX



KKK6BX



KKK6NX



KKK6TV



KKK8TV

Piani MDF - MDF tops



KKK4B



KKK4N



KKK5B



KKK5N

Piani melaminico - Melaminic tops

Serie di tavoli attesa caratterizzati da:

- piani tondi o quadri in vari materiali;
- basi tonde o quadre in acciaio verniciato bianco opaco, in acciaio inox satinato o lucido;
- basi 4 razze in acciaio cromato
- telai 4 gambe in acciaio verniciate color alluminio.

Series of coffee tables available with:

- round or square tops in different materials;
- round or square bases in mat white painted steel, in satin or polished stainless steel;
- 4-star chromed steel bases
- 4-leg aluminum painted steel frames.

Gamme de tables attente caractérisés par:

- plateaux ronds ou carrés en différents matériaux;
- piétements ronds ou carrés en acier verni blanc opaque, en acier inox satiné ou poli;
- piétements à 4-branches en acier chromé;
- structures à 4-pieds en acier vernie alu.

Serie von Couchtischen bestehend aus:

- Platte rund oder quadratisch in verschiedenen Materialien;
- Gestelle rund oder quadratisch aus Stahl matt weiß lackiert, aus Edelstahl satiniert oder poliert;
- 4-Stern Gestell aus Stahl verchromt;
- Vierfuß aus Stahl alugrau lackiert

Serie de mesas de espera caracterizadas por:

- encimeras redondas o cuadradas en diferentes materiales;
- bases redondas o cuadradas en acero pintado blanco opaco o en acero inox satinado
- bases de 4 radios en acero cromado
- estructuras de 4 patas en acero pintadas color aluminio.



Piano tondo bianco in HPL (bordo inclinato)
HPL white round top (inclined side)

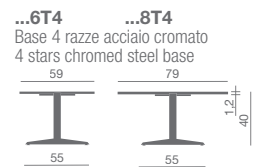
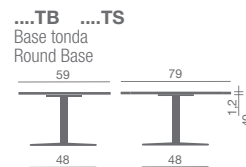

Piano quadro bianco in HPL (bordo inclinato)
HPL white squared top (inclined side)

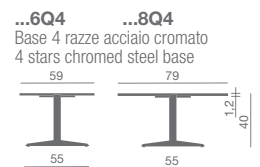
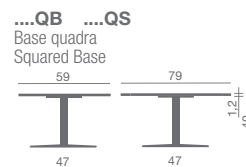

Piano tondo bianco/nero in MDF
Round white/black MDF top

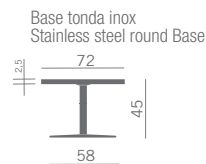

Piano quadro bianco/nero in MDF
Squared white/black MDF top

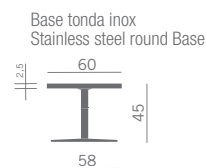

Piano melaminico bianco/nero
Melaminic white/black top





Rivestimenti

Textiles and Leathers

Revêtements

Bezüge

Tejidos

- Colori, tessuti e pelli fotografati sono indicativi
- Colours, fabrics and leathers photographed are indicative



A

Categoria
Category

PLANET
Resistenza alla fiamma - Fire resistance
Certificato Classe 1 UNI 9175 CL. 1 IM
87,5% P.V.C. plastificato - 12,5% cotone
(Martindale 70.000)



A 31 F



A 32 F

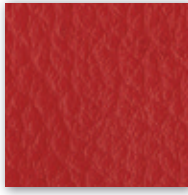

A 39 F

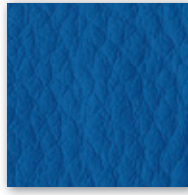

A 35 F



A 34 F



A 38 F



A 36 F



A 33 F



A 27 F

B

Categoria
Category

Tessuto altamente ignifugo
Certificato Classe 1 Ministero dell'Interno
Fireproof fabric - Tissu non feu
Brandfester Bezug - Tela ignifuga
100% MA - FRS acrilico
(Martindale 55.000)



B 251

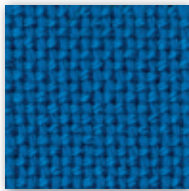

B 264

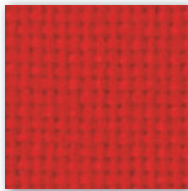

B 259

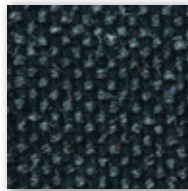

B 267



B 266 (Dark brown)

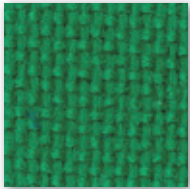

B 262

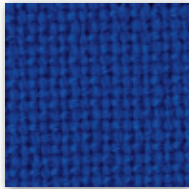

B 263

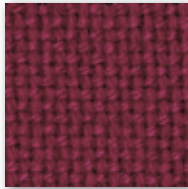

B 265



B 254

C

Categoria
Category

SKILL
Resistenza alla fiamma - Fire resistance
Certificato Classe 1 UNI 9175 CL. 1IM - EN 1021 - BS 5852
69% P.V.C. plastificato - 30% cotone - 1% poliuretano
(Martindale 50.000)



SKILL



C 40 F



C 41 F



C 42 F

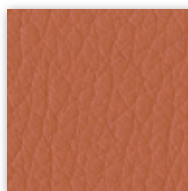

C 43 F



C 44 F

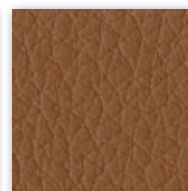

C 45 F

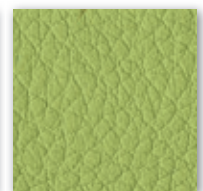

C 46 F

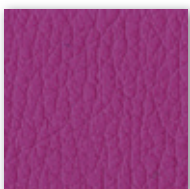

C 47 F



C 48 F



C 49 F

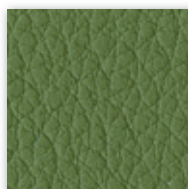

C 50 F

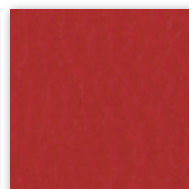

C 51 F

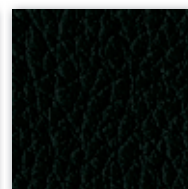

C 52 F

C

Categoria
Category

TREVI Tessuto altamente ignifugo
Certificato Classe 1 Ministero dell'Interno
Fireproof fabric - Tissu non feu
Brandfester Bezug - Tela ignifuga
100% Poliestere Trevira CS
(Martindale 120.000)

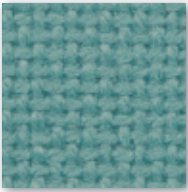

C 321

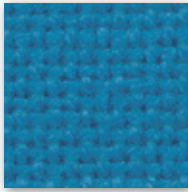

C 314

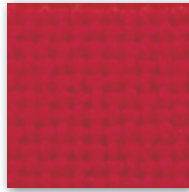

C 300



C 311

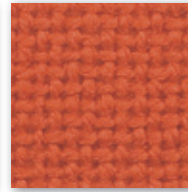

C 323

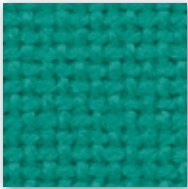

C 306

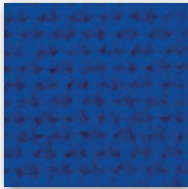

C 319

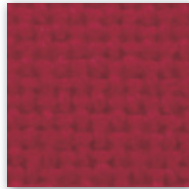

C 316

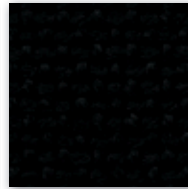

C 310

C

Categoria
Category

Tessuto altamente ignifugo
Certificato Classe 1 Ministero dell'Interno
Fireproof fabric - Tissu non feu
Brandfester Bezug - Tela ignifuga
100% Poliestere Trevira CS
(Martindale 100.000)

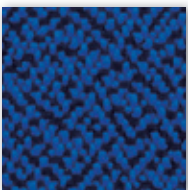

C 360

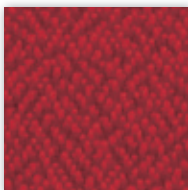

C 361

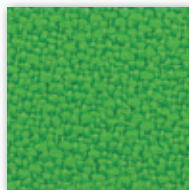

C 359

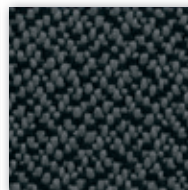

C 363



C 364

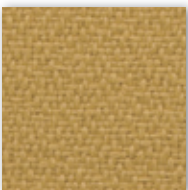

C 366

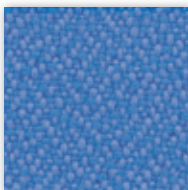

C 367

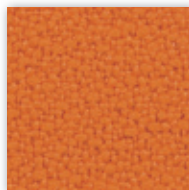

C 368

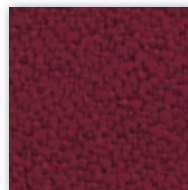

C 369

C

Categoria
Category

Tessuto altamente ignifugo
Certificato Classe 1 Ministero dell'Interno
Fireproof fabric - Tissu non feu
Brandfester Bezug - Tela ignifuga
100% Poliestere Trevira CS
(Martindale 55.000)

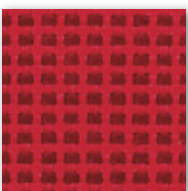

C 396

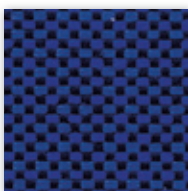

C 397

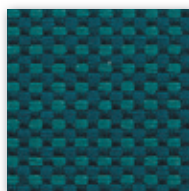

C 398

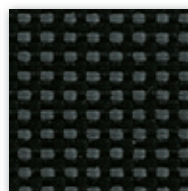

C 399

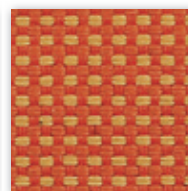

C 395

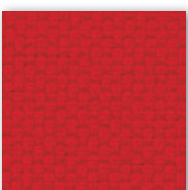

C 390

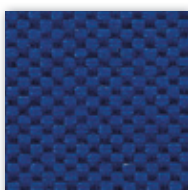

C 391

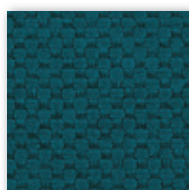

C 392

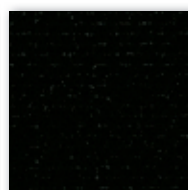

C 393

C

Categoria
Category

TREVI Tessuto altamente ignifugo
Certificato Classe 1 Ministero dell'Interno
Fireproof fabric - Tissu non feu
Brandfester Bezug - Tela ignifuga
100% Poliestere Trevira CS
(Martindale 70.000)



C 381



C 38 T

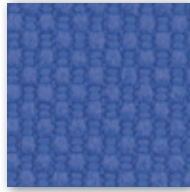

C 383

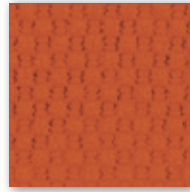

C 380



C 385

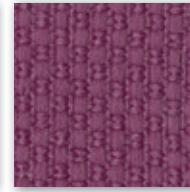

C 38 L



C 38 H



C 382



C 386



C 387

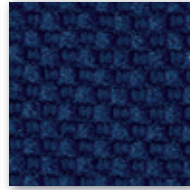

C-38

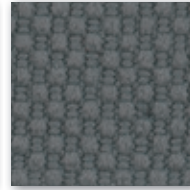

C 384

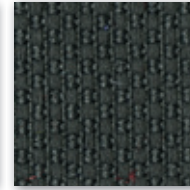

C 38 A

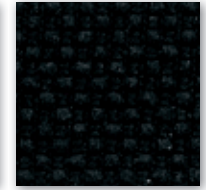

C 388

C

Categoria
Category

Tessuto altamente ignifugo
Certificato Classe 1 Ministero dell'Interno
Fireproof fabric - Tissu non feu
Brandfester Bezug - Tela ignifuga
100% Xtreme FR®
(Martindale 100.000)

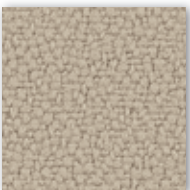

C 335

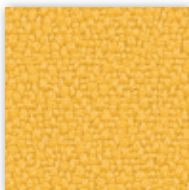

C 336



C 332

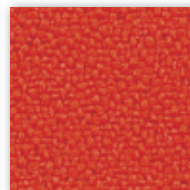

C 334

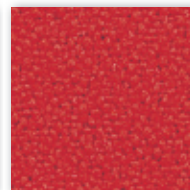

C 329

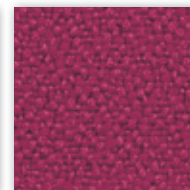

C 337



C 327 (Dark brown)

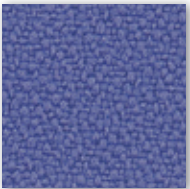

C 339

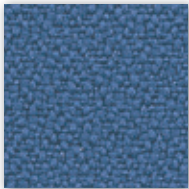

C 325

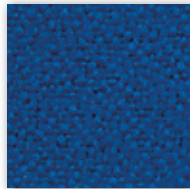

C 326

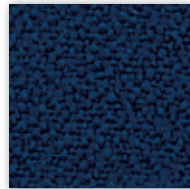

C 330

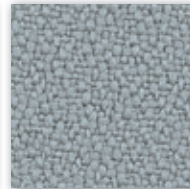

C 331

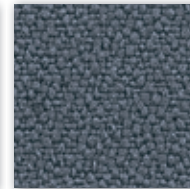

C 324



C 328

D

Categoria
Category

Rete - Mesh - Resille - Membran - Red
64% PL - 36% PA - Martindale 100,000

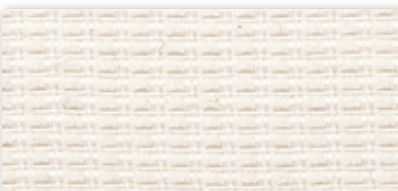

D 218



D 219

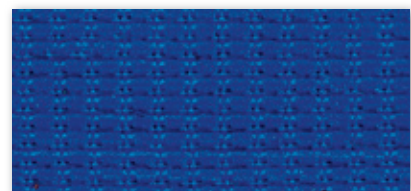

D 220

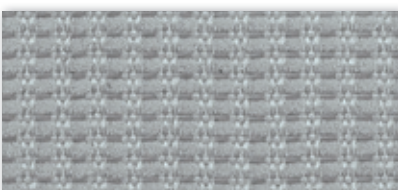

D 221

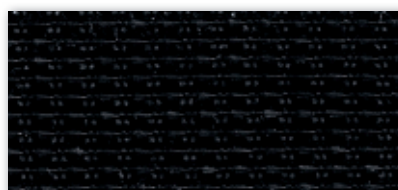

D 222

D

Categoria
Category

Trattamento antimicrobico - Antimicrobial treatment
Resistenza alla fiamma - Fire resistance
UNI 9175 CL. 1IM - EN 1021-2 - BS 5852-1 part I
63% Poliuretano - 29% Cotone - 8% PES
63% Polyurethane - 29% Cotton - 8% PES
(Martindale 150.000)

EXTREMA/AU
Ultra-Fresh*



D 420



D 426



D 430

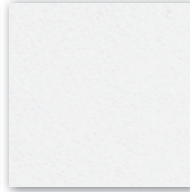

D 427



D 431

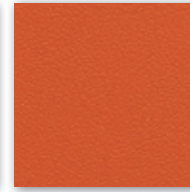

D 421



D 423



D 432



D 422

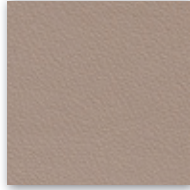

D 425

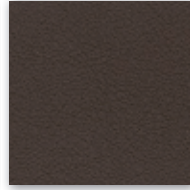

D 428 (Dark brown)



D 424

D

Categoria
Category

Resistenza alla fiamma - Fire resistance
UNI 9177 CL. 1 - UNI 9175 CL. 1IM - EN 1021-2
100% PES
(Martindale 60.000)

ESEDRA



D 450



D 451



D 452



D 453

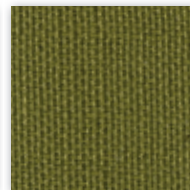

D 454

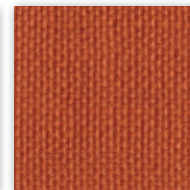

D 455



D 456



D 457



D 458

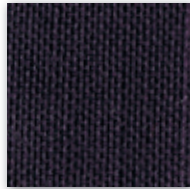

D 459



D 460



D 461

D

Categoria
Category

Trattamento fungicida - Resistance to mould and bacteria
Impermeabilità - Waterproof
Resistenza alla fiamma - Fire resistance
UNI 9175 CL. 1IM - EN 1021-2 - BS 5852-1 part I
63% Poliuretano - 29% Cotone - 8% PES
63% Polyurethane - 29% Cotton - 8% PES
(Martindale 150.000)

EXTREMA IKON
Ultra-Fresh*



D 470



D 471



D 472

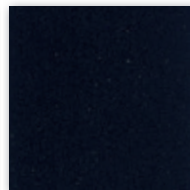

D 473

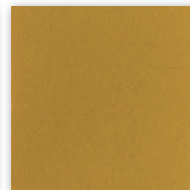

D 474

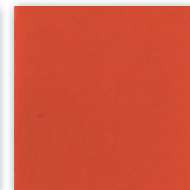

D 475



D 476

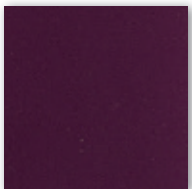

D 477

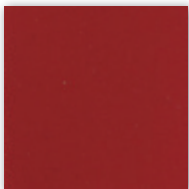

D 478

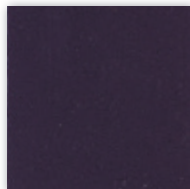

D 479

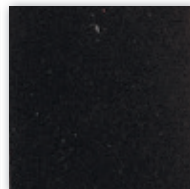

D 480

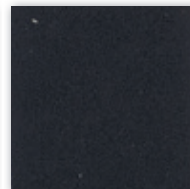

D 481

D

Categoria
Category

Tessuto altamente ignifugo
Certificato Classe 1 Ministero dell'Interno
Fireproof fabric - Tissu non feu
Brandfester Bezug - Tela ignifuga
100% Poliestere Trevira CS
(Martindale 110.000)



TREVIRA
CS

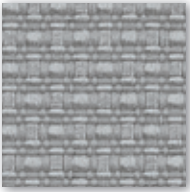

D 440

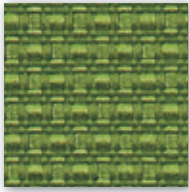

D 441

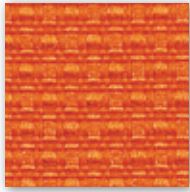

D 442

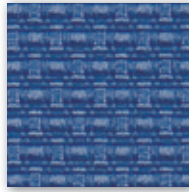

D 443



D 444



D 445



D 446



D 447



D 448

P

Categoria
Category

DIVINA 3
100% Lana vergine - New wool
Resistenza alla fiamma - Fire resistance
Certificato classe 1 UNI 9175 1IM - EN 1021-1/2 - BS 5852
(Martindale ~ 45.000)



PK 951 (Divina 224)

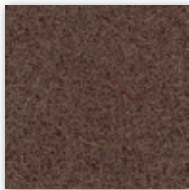

PK 952 (Divina 356)



PK 953 (Divina 856)



PK 954 (Divina 956)

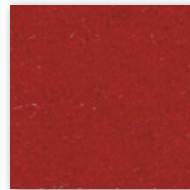

PK 955 (Divina 623)

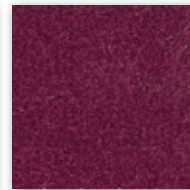

PK 956 (Divina 652)



PK 950 (Divina 676)



PK 957 (Divina 666)



PK 958 (Divina 696)



PK 959 (Divina 742)

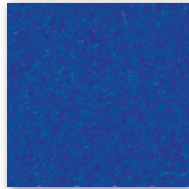

PK 960 (Divina 756)

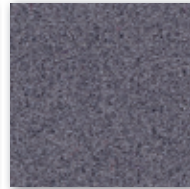

PK 961 (Divina 154)

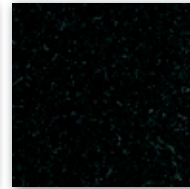

PK 962 (Divina 191)

P

Categoria
Category

Vera pelle - Genuine leather
Cuir - Leder - Piel auténtica
A richiesta disponibili altri colori.
By request any other colours available.



VERA
PELLE



P 901

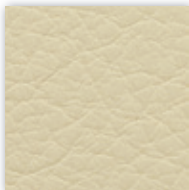

P 915



P 916



P 917

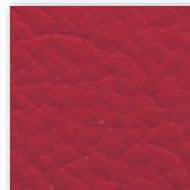

P 909

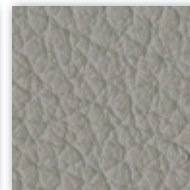

P 905



P 911

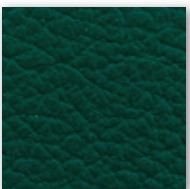

P 910

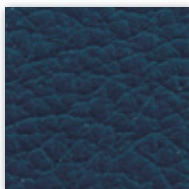

P 912

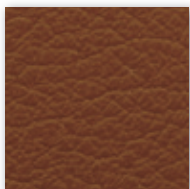

P 908



P 902 (Dark brown)

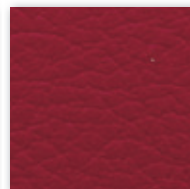

P 914

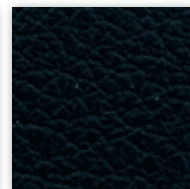

P 903

KICCA
KALEA

Colori polipropilene
Polypropylene colours



C

Crema
Cream
Crème
Creme
Crema

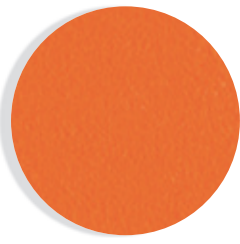

A

Arancio
Orange
Orange
Orange
Naranja



B

Blu
Blue
Bleu
Blau
Azul

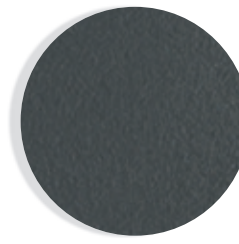

G

Grigio
Grey
Gris
Grau
Gris



T

Tortora
Dove-colour
Tourterelle
Taube
Arena

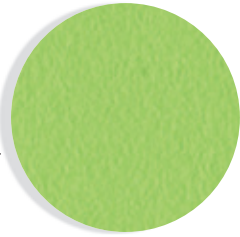

V

Verde
Green
Vert
Grün
Verde



R

Rosso
Red
Rouge
Rot
Rojo



N

Nero
Black
Noir
Schwarz
Negro

KRIZIA

Colori policarbonato
Polycarbonate colours



B

Bianco
White
Blanc
Weiss
Blanco

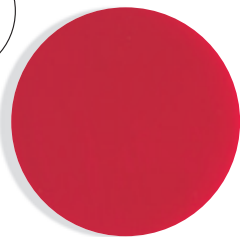

R

Rosso
Red
Rouge
Rot
Rojo



N

Nero
Black
Noir
Schwarz
Negro

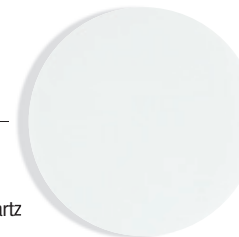

B

Bianco
White
Blanc
Weiss
Blanco



M

Moka



N

Nero
Black
Noir
Schwarz
Negro

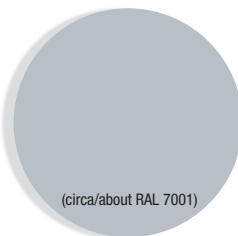

G

Grigio
Grey
Gris
Grau
Gris

(circa/about RAL 7001)

KENSHO
KAPPO

Colori piani-basi
Tops-bases colours



B

Bianco
White
Blanc
Weiss
Blanco

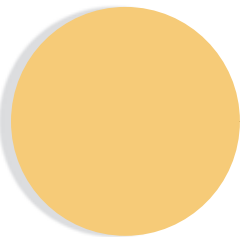

G

Giallo
Yellow
Jaune
Gelb
Amarillo

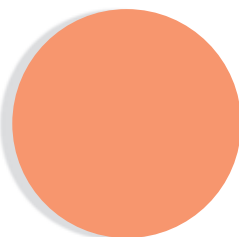

A

Arancio
Orange
Orange
Orange
Naranja



Rovere
Oak
Rouvre
Eichenholz
Roble

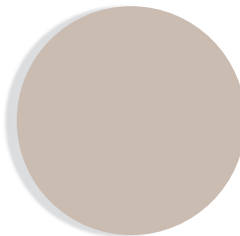

T

Tortora
Dove-colour
Tourterelle
Taube
Arena

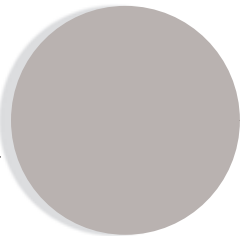

L

Lava



Faggio bianco
White beechwood
Hêtre blanc
Buchenholz weiss
Haya blanca

KIMBOX



REFERENCE LIST

Abu Dhabi Commercial Bank (U.A.E.)
Airport Moscow (Russia)
Airport Prishtina International · Prishtina (Kosovo)
Al Ain Municipality Project (U.A.E.)
Aljawal-Teleph. Riyadh (Saudi Arabia)
Allianz Assicurazioni Spa (Italy)
Amabsciata Austriaca (Belgium)
Ambasciata D'Italia Buenos Aires (Argentina)
Amphitheatre Cyprus (Cyprus)
Assicurazioni Generali Spa (Italy)
ASL 1 · Gubbio (Italy)
Aventis (l'Oréal) Paris (France)
Azienda Agricola L'argenteria · Firenze (Italy)
Banc Maroc Casablanca (Maroc)
Banca Cattolica Montefiascone (Italy)
Banca Ifis (Italy)
Banco Gallego (Spain)
Bank of Cyprus · Athen (Greece)
Bank of Cyprus (Cyprus)
Bank of Mauritius (Mauritius)
Banque Populaire France (France)
Bartolini Spa (Italy)
Caixa Girona (Spain)
Caja Ahorros Sevilla (Spain)
Caja Monte Piedod (Spain)
Cajasal (Spain)
Castiglion Del Bosco Resort · Scarlino (Italy)
Central Bank Of Moscow (Russia)
Colegio de Abogados de Gerona (Spain)
Compass Spa (Italy)
Comune San Miniato · Pisa (Italy)
Deloitte Malta (Malta)
Edition La Martiniere Paris (France)
Dubai Police (U.A.E.)
Embassy Of Russian Federation · London (U.K.)
Emirates Bank Dubai (U.A.E.)
Ferrari Auto Spa · Maranello (Italy)
Fincantieri Spa (Italy)
Fineco Leasing (Italy)
Fondiaria Assicurazioni Spa (Italy)
Fondazione Casse di Risparmio Orvieto (Italy)
Golf Club Chamonix (France)
Grand Hotel Bellevue (Belgium)
Grand Hotel Italia · Orvieto (Italy)
Gruppo Savino del Bene · Livorno (Italy)
Hansabank (Czech Republic)
HBSC Bank (France)
Hilal bank Dubai (U.A.E.)
Hillebrand Spa Bolgheri (Italy)
Hoferbueros GmbH Gelsenkirchen (Germany)
Hôpital des Armées Percy (France)
Hotel de Cantharel Apeldoorn (Netherland)
Hotel Cesar · Montegrotto Terme - Padova (Italy)
Hotel De Diane (France)
Hotel Four Seasons · Montalcino (Italy)
Hotel -4-Stars City Season (Oman)
Hotel Intercontinental (Saudi Arabia)
Hotel Sheraton Deira Hotel (U.A.E.)
Hotel Park Bohinj (Slovenia)
Hotel Projet (New Zeland)
I.N.P.S. (Italy)
I.N.A.I.L. Fori (Italy)
Ina Assitalia Assicurazioni (Italy)
Istituto Universitario Europeo · Firenze (Italy)
Junta de Andalucia (Spain)
Kempinski Hotel Grand Arena B. (Bulgaria)
Kuwait Real Estate Bank (Kuwait)
Lavicosmetical- L'Oreal (Greece)
L'Oreal Hong Kong (HK)
Lloyd Adriatico Assicurazioni Spa (Italy)
Luxottica Spa (Italy)
Luxottica Spa London (U.K.)
Luxottica Spa New York (U.S.A.)
Maire de Bras Panon Ile De La Reunion (La Reunion)
Mc Cann Ericson · Milan (Italy)
Mc Donald's Budapest (Hungary)
Ministero Affari Esteri · Roma (Italy)
Ministero Del Tesoro · Roma (Italy)
Ministero Dell'Interno · Roma (Italy)
Ministero Economia (Portugal)
Ministry of Information Trinidad & Tobago (Trinidad & Tobago)
Ministry of Trade Trinidad & Tobago (Trinidad & Tobago)
Ministry of Work Trinidad & Tobago (Trinidad & Tobago)
Ministry Planning & developpement Trinidad & Tobago (Trinidad & Tobago)
Ministry of Culture Abu Dhabi (U.A.E.)
Mobilis Annecy (France)
Mobily Jeddah (Saudi Arabia)
Movistar (Spain)
Municipality of Dubai (U.A.E.)
Museo del Vino Montefalco (Italy)
Neuremd Venafro (Italy)
Nouvelles Frontieres (France)
Politecnico di Milano (Italy)
Presidenza Del Consiglio Dei Ministri Roma (Italy)
Regione Siciliana · Palermo (Italy)
Rocchegiani Spa · Camerino (Italy)
Roger Debuis (Switzerland)
Rolls Royce U.K. (U.K.)
Safilo Spa (Italy)
Santander bank (Portugal)
Seminario Arcivescovile Reggio Calabria (Italy)
Servicios centrales de Patrimonio (Spain)
Sherman and Sterling Paris (France)
Siemens Italia · Milano (Italy)
Société Generale Salle de Trader Paris (France)
Sous Prefecture De Bayonne (France)
Sorgenia Spa · Milano (Italy)
Study Group Brighton (U.K.)
Tata Consulting London (U.K.)
Tbc Bank Georgia (Georgia)
Telecom Portugal (Portugal)
Terminale Stazione Minimetro Perugia (Italy)
Toro Assicurazioni Spa Italy (Italy)
Trenitalia (Italy)
Tui Airlines (Belgium)
Ufficio delle Dogane Roma (Italy)
Università Macerata (Italy)
Università Reggio Calabria-Facoltà agraria (Italy)
Università Torvergata Roma (Italy)
Università Perugia (Italy)
University of Brno - Masaryk Brno (Czech Republic)
Université de Liege (Belgique)
University Science & Tec. King Abdullah (Saudi Arabia)
University Of The Art U.K. (U.K.)
University of Zagreb (Croatia)
Veka Group (France)
Vigili del Fuoco · Roma (Italy)
Vimpelcom Russia (Russia)
Vodafone Kuwait Safat (Kuwait)
Vodafone Malta (Malta)
Yacht Service La Marina di Scarlino (Italy)



Art direction

Arch. FRANCO DRIUSSO

Graphic design

DRIUSSOASSOCIATI | ARCHITECTS

Photo

ANDREA PANCINO - RENAI&RENAI

Print

TIPSE