

LOUNGE & SOFT FURNITURE



232

TANGO Lounge
> 234



ARCIPELAGO Wood
> 248



VEGAS
> 258



DANAE
> 262

233



TANGO
> 238



JAZZ Chill Out
> 254



CUMULUS
> 259



MEG
> 264



ARCIPELAGO
> 242



GIRO
> 256



TULA
> 260



LUNA
> 265

TANGO Lounge

Design by Christina Strand and Niels Hvass

VISITOR CHAIRS	HIGH CHAIRS	LOUNGE & SOFT FURNITURE
> 202	> 226	> 238

234



reddot award 2019
winner

An exclusive design of TANGO Lounge chair will be a spotlight of any office. It has a well-rounded high backrest shelter which isolates the users from surrounding noise, giving them a sense of comfort, protection, and minimizing distractions. The seat of the TANGO Lounge is wider than a typical size seat, thus it allows you to relax and enjoy an ultimate sense of comfort. The chair will add a special touch to both formal and informal meeting spaces or relaxation areas.



**LOUNGE
& SOFT
FURNITURE**

Distinctive
character and
freedom of
expression for
your style

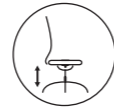

PNEUMATIC HEIGHT
REGULATION

236

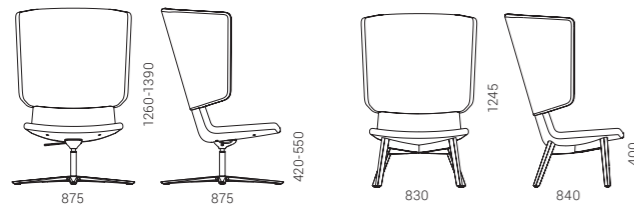

TANGO Lounge

Beauty of contrast

You can select different colour combinations for the upholstered part of the chair. Contrasting colours will bring a sense of exclusivity to your TANGO furniture. It also comes in a variety of different base options so there is no need to compromise on style. When choosing the right one, consider your functional needs as well as the fabric or design to accommodate your preferences.



TANGO

Design by Christina Strand and Niels Hvass

VISITOR
CHAIRS
> 202

HIGH
CHAIRS
> 226

LOUNGE
& SOFT
FURNITURE
> 234



238

TANGO lounge furniture stands out for its minimalist and clean refined lines as well as strong visual identity. The rounded edges and smooth transitions between the backrest and the armrests offer a comfortable seating position even if the work meeting lasts longer than expected.

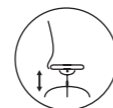

PNEUMATIC HEIGHT
REGULATION

TANGO chairs with metal bases have a more modern look, whereas the wooden ones give the office a more homely feel and at the same time add more elegance to the room. Both base options are available in dark and light colours to further add to the beauty of contrast.

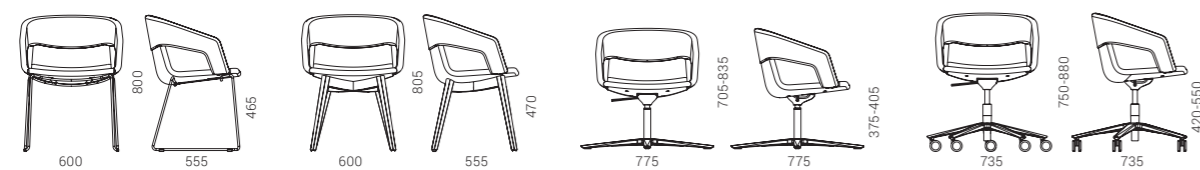

TANGO



With its visually striking Scandinavian design, TANGO soft seating family is perfect for modern offices that exude a chic vibe and looks just as nicely in traditional office spaces. Like the tango dance itself, it has expressive character, provides improvisational freedom and comes in different style variations.

TANGO

LOUNGE
& SOFT
FURNITURE



TANGO

TANGO

Design by Baldanzi & Novelli designers

Release your creativity with ARCIPELAGO!

Arcipelago is a modular lounge seating system offering endless configuration possibilities. Choose your favourite configuration from our wide range of standard options or build your custom configurations by mixing and matching modular components. ARCIPELAGO modular configurable system is easy to assemble, disassemble, or reassemble.



242



ARCIPELAGO



Playful colours

243

Choose from our wide range of fabrics and colours or mix and match them to create a unique atmosphere for your office. The backrest and seat cushions can be easily removed and swapped.

ARCIPELAGO

**LOUNGE
& SOFT
FURNITURE**

3 heights

Thanks to their flexibility and 3 different height options, ARCIPELAGO lounge benches are a great choice for spaces of any size and style. The high-back option will provide you with more privacy and acoustic comfort.

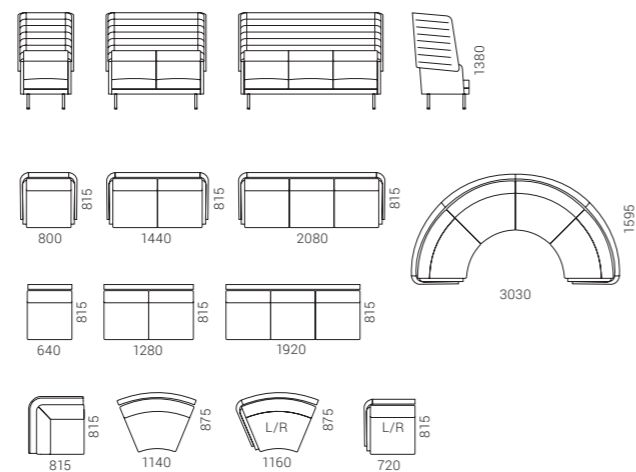
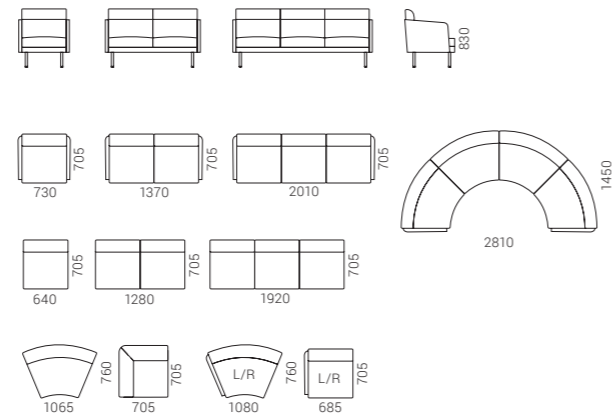
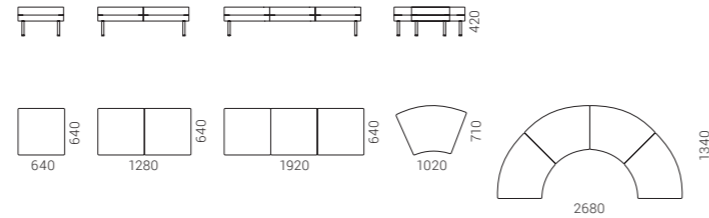

244

Useful accessories

Lounge benches come with well-designed accessories. You can choose a table or armrest with or without an integrated power socket or USB fast charger. Both of these can be easily mounted in between the seats.

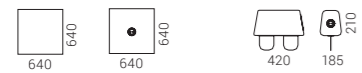

**LOUNGE
& SOFT
FURNITURE**





LOUNGE
& SOFT
FURNITURE

ARCIPELAGO

Wood

Design by Baldanzi & Novelli designers

LOUNGE
& SOFT
FURNITURE

> 242

Escape busy office environment

ARCIPELAGO Wood lounge seating is ideal for creating an enclosed "room within a room" in open-plan offices. It serves as a meeting and work space where you can isolate yourself from ambient noise. This lounge seating is ideal for multiple uses: brief tasks or longer work sessions, meetings, teamwork or relaxation.

248



ARCIPELAGO Wood

Design

ARCIPELAGO Wood has been designed by the Italian design studio Baldanzi & Novelli Designers. Aesthetic design, smooth shapes and natural elements bring a sense of warmth to the office.





Functionality

The seating unit can accommodate a monitor screen for convenient presentation of information during business meetings. The table is equipped with a power socket with integrated USB type A and C connectors for any work devices to make sure you never run out of energy.

251

Comfort

Baldanzi & Novelli Designers who created ARCIPELAGO Wood compares this piece of furniture to an island which offers a natural retreat. ARCIPELAGO Wood high panels serve as barriers shielding employees from background noise while comfortable seating creates a laid-back and private environment.

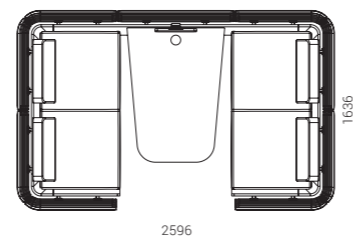
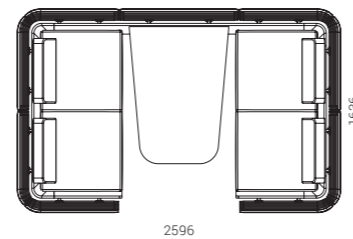

**LOUNGE
& SOFT
FURNITURE**



JAZZ Chill Out

Design by Christina Strand and Niels Hvass

Freedom of improvisation

JAZZ Chill Out is an easily customizable pouf system for any lounge or waiting area in your office. A wide selection of fabric, artificial, and natural leather finishes opens up unlimited possibilities to create the desired interior atmosphere.

254



Convenient details for contemporary people

For the convenience of users, the poufs have an integrated plug or USB fast charging socket - an extremely practical solution for not only office workers but for visitors as well. Another functional highlight of this system is the metal table, which can be easily placed on the surface of the pouf to protect objects from falling.

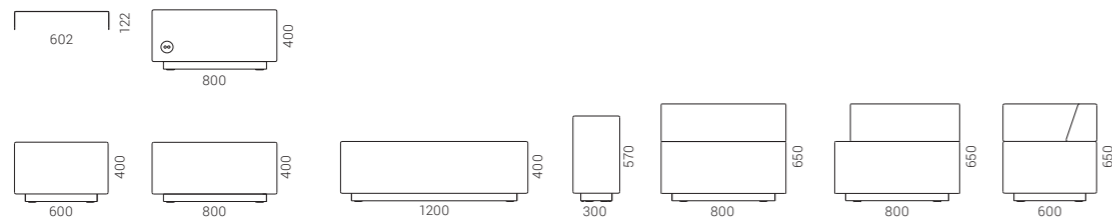

A true colour pallet
at your office



GIRO pouf system is a great way to liven up any office environment and create the desired mood by choosing matching or contrasting colours. A wide selection of fabric, leather look and genuine leather is available for this pouf system upholstery. Small, lightweight, and mobile GIRO can be effortlessly rearranged in space.

256

Customizable design

Variation of three different diameters and three different heights allows the user to choose the one that best suits their needs - it can be used both for sitting at a colleague's workplace or placed in the waiting and lounge areas. There are 2 base options available for GIRO system - with plastic glides or castors. Choosing plastic supports will create a more tidy office look while choosing castors will allow you to move the furniture around without much effort.

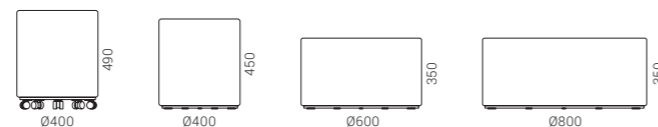

VEGAS

A temptation
to relax

A curved shape, lower and wider
seating area implies a welcoming
invitation to have a seat for
anyone passing by.

258



The chair shell can be upholstered with different
fabric combinations, leather look, or genuine leather.
Chromed steel sled frame base create a distinctive
character and provide durability while plastic glides
help prevent floor damage.

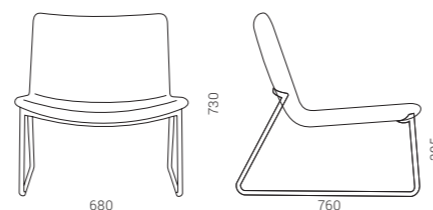

VEGAS

CUMULUS

Design by Kazuko Okamoto



259

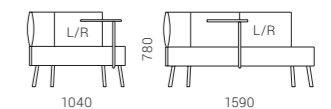
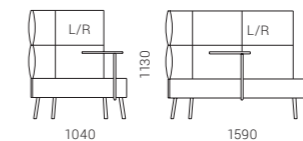
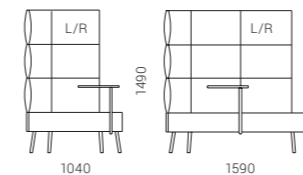
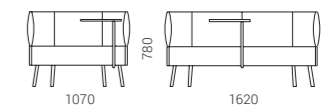
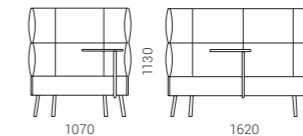
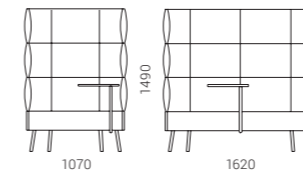

CUMULUS

Designed to bring comfort

It is a perfect fit for lounge and waiting areas or informal meeting spaces. The distinctive design of the chair is made to wrap itself around the user and provide not only a comfortable sitting experience but also coziness.

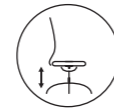

PNEUMATIC HEIGHT
REGULATION

260



Custom features for unique looks

TULA chairs are highly customizable as you can select individual colours for the front and back parts of the chair. You can even mix and match different materials for the separate parts of the upholstery. With our wide selection of fabric, leather look, genuine leather, the chairs can be adapted for a number of unique situations and looks.

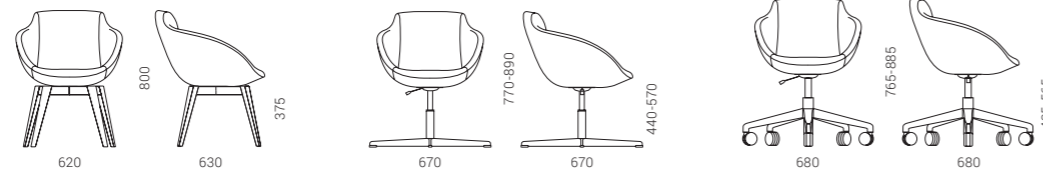

Make your office stand out

This chair is a perfect combination of elegance and comfort. A charming silhouette creates a sophisticated look and a welcoming feeling that is why this chair will perfectly blend in any conference room or waiting area.

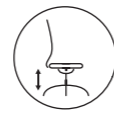

PNEUMATIC HEIGHT
REGULATION

262

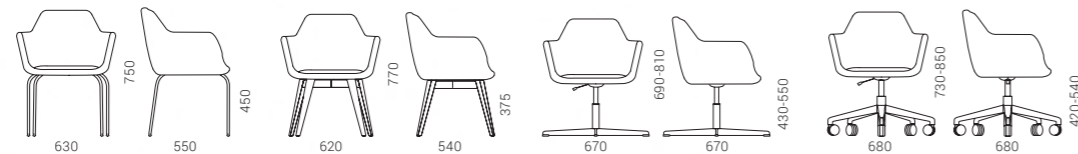

MEG

A distinctive addition
to your office

With its contemporary shape, MEG lounge chair will definitely find a place in any office space. A laconic design will suit those who appreciate a moderate style.

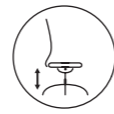

PNEUMATIC HEIGHT
REGULATION



264



MEG

LUNA

A proven design
that lasts

Stylish and refined, this lounge chair represents a classic approach to the office design. A simple yet timeless look makes LUNA a wise choice.

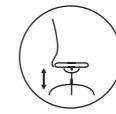

PNEUMATIC HEIGHT
REGULATION



265

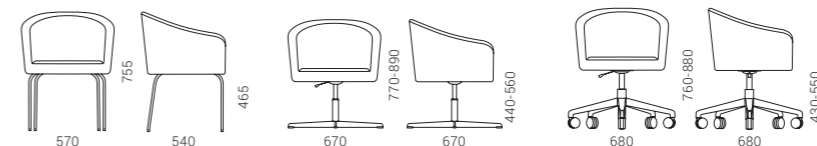

LUNA

MATERIALS

SURFACE
MATERIALS
> 322

UPHOLSTERY
MATERIALS
> 323



SURFACE MATERIALS

Melamine



HPL

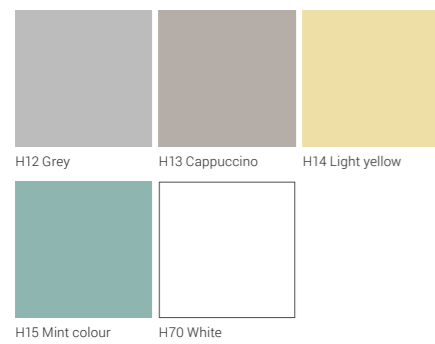

322

Veneer

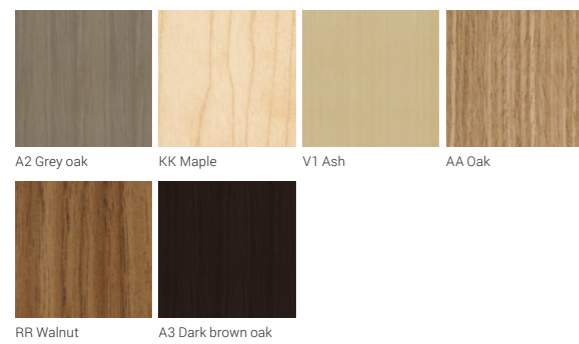

Plexiglas®

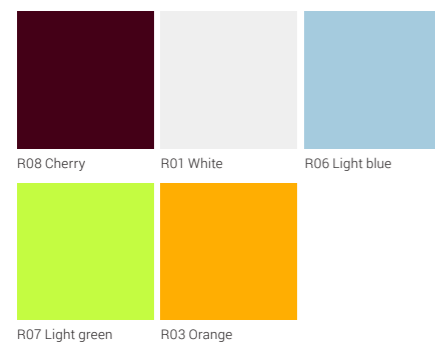

SURFACE MATERIALS

UPHOLSTERY MATERIALS

Synergy

95% Virgin Wool, 5% Polyamide

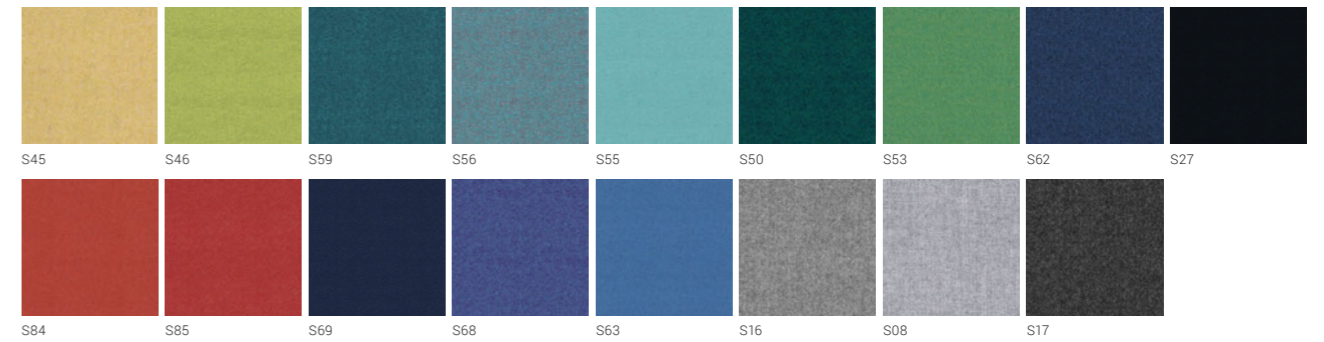

HPL Fenix

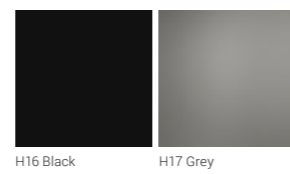

Velito | Velito Presto

88% Wool, 12% Polyamide

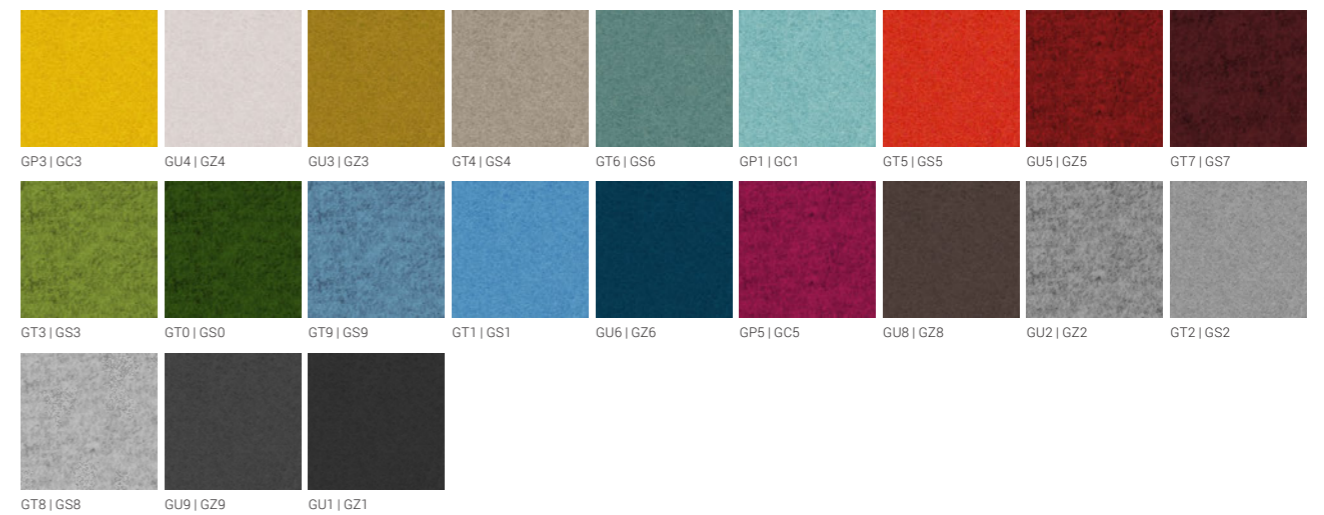

323

Solid wood

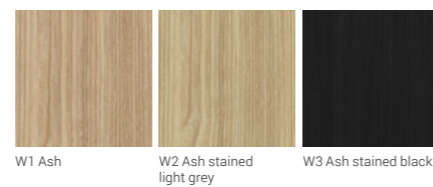

Step | Step Melange

100% Trevira CS®
Flame Retardant Polyester

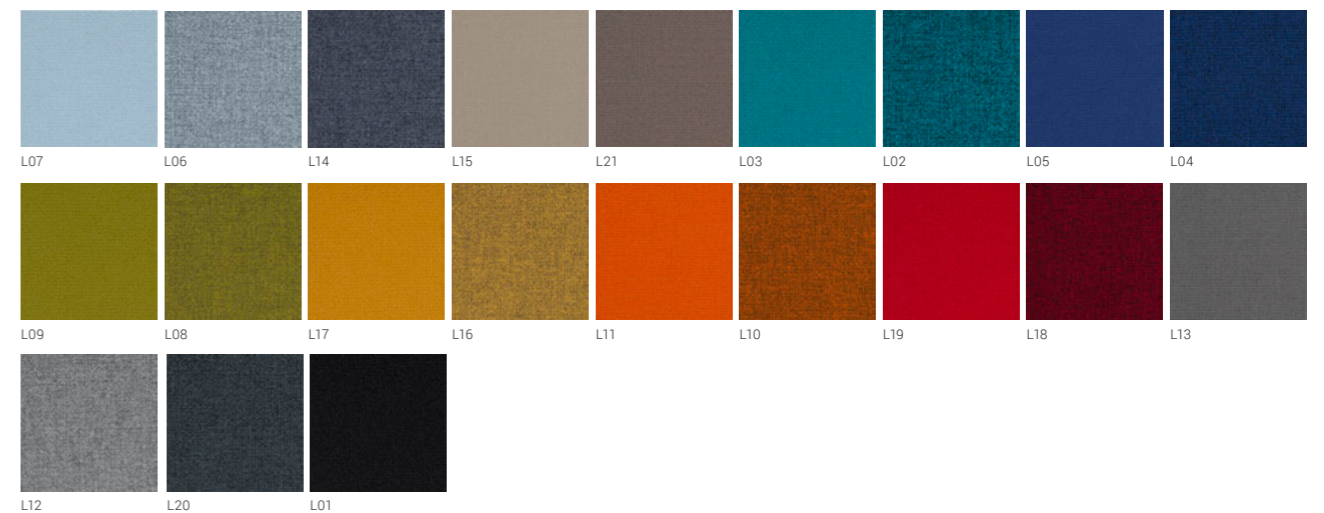

UPHOLSTERY MATERIALS

Metal

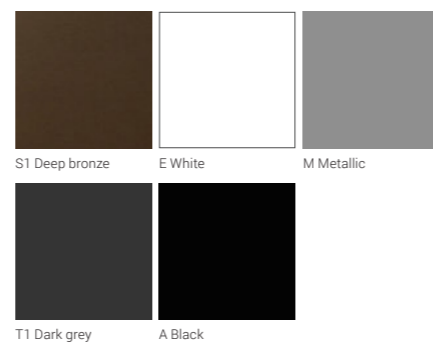

UPHOLSTERY MATERIALS

Era

100% Polyester

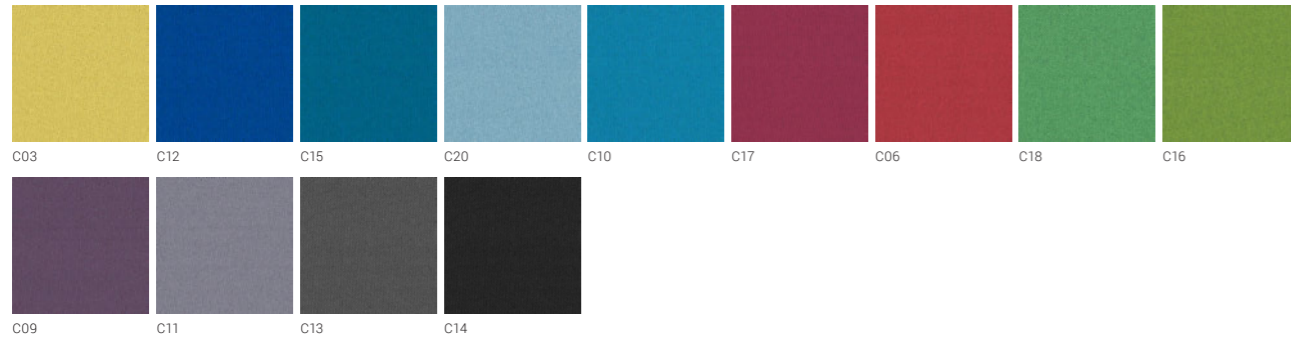

UPHOLSTERY MATERIALS

Bondai

100% Polyester



Berta

100% Polyester

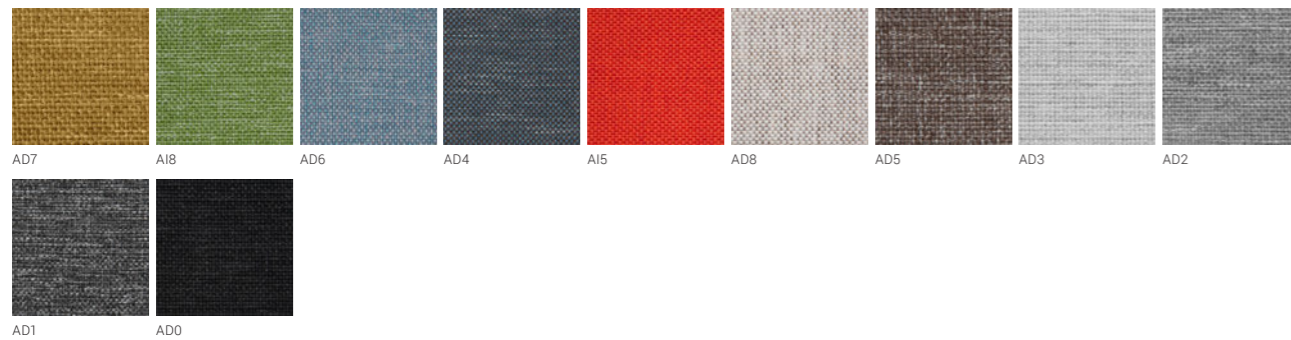

RNN

21% PES, 31,5% COT, 47,5% PU



324

DNN 

Real leather

325



Xtreme Plus

100% Recycled Polyester

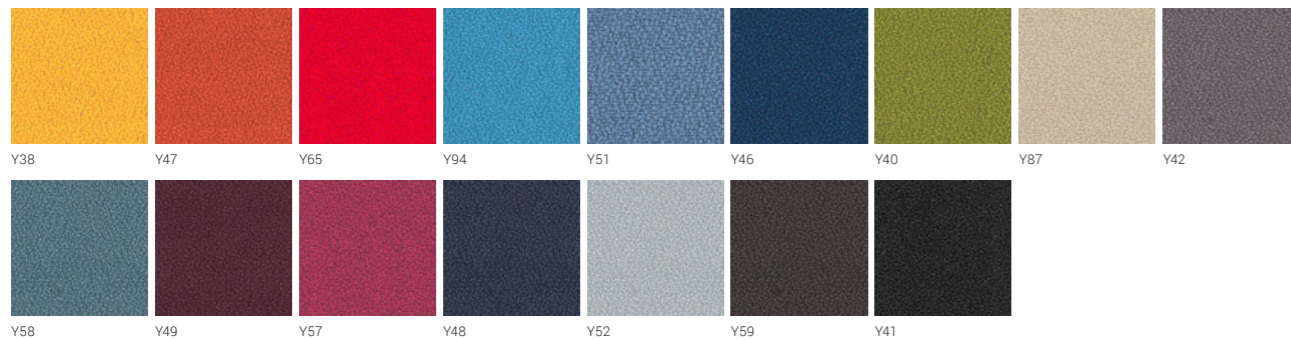

Micro

100% Polyester

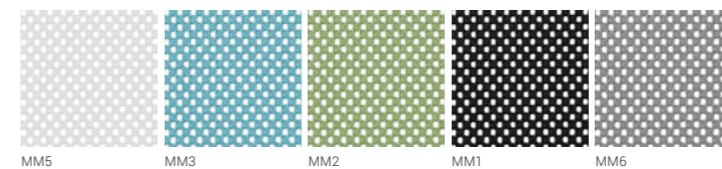

GM

100% Polyester

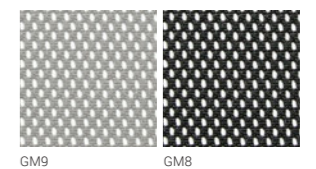

Lucia

100% Recycled Polyester

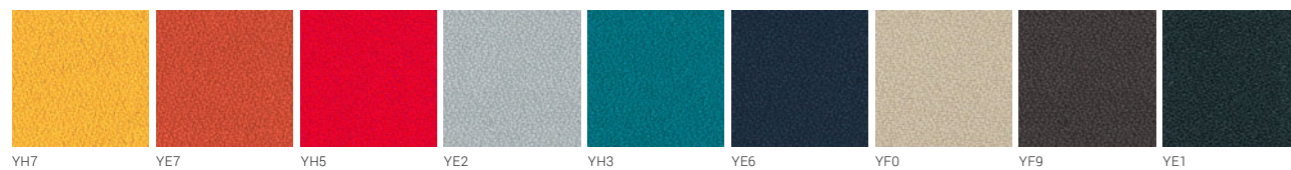

Knitted mesh

100% Polyester

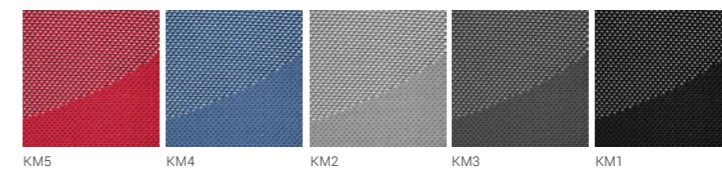

PM

70% PVC, 30% PES

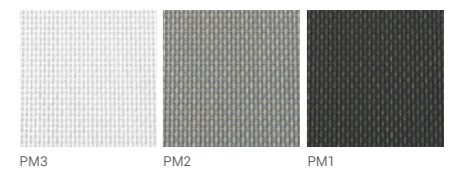

Definition of icons



TILT MECHANISM

The backrest and seat base are linked. When user leans back the whole chair tilts.



KNEE TILT MECHANISM

The backrest and seat base are linked. When user lean back the whole chair tilts. This mechanism allows user to tilt back while the feet remain on the floor, no pressure on the back of the shin.



SYNCHRONOUS MECHANISM

The seat tilting angle is smaller than the tilting angle of the backrest, so that the chair would be more comfortable. This mechanism allows user to tilt back while the feet remains on the floor, no pressure on the back of the leg.

326

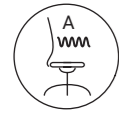

WEIGHT-SENSITIVE MECHANISM

Mechanism automatically adapts to the user's weight and movement when leaning back.



TENSION ADJUSTMENT

This adjustment allows user to control the rate and ease with which the chair reclines for different weights and strengths.



LOCKING POSITIONS

The backrest of the chair has multiple locking positions with different angles for comfortable working, reading or resting.

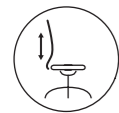

BACKREST HEIGHT ADJUSTMENT

The backrest height can be individually adjusted according to the height of the user.



SLIDE SEAT

This adjustment helps the user to regulate the distance between the backrest and front edge of then seat, thus providing optimum support for the upper thighs. Correctly adjusted seat depth helps user to maintain proper back support, while distributing the weight evenly across the seat cushion.

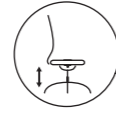

PNEUMATIC HEIGHT REGULATION

This adjustment allows the user to change the height of the seat. Pneumatic mechanism uses pressurized air to lift or lower the seat.

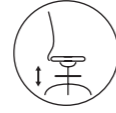

HEIGHT ADJUSTABLE FOOTRING

The footring of the chair can be adjusted in height for the comfortable position of user's feet and legs without depending on the chair height position. It helps to maintain a correct seating position and avoid unpleasant back and neck pain.

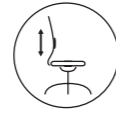

ADJUSTABLE LUMBAR SUPPORT

The lumbar support can be adjusted in height and depth (depending on the chosen chair type). Adjustable lumbar support can be adapted to user's individual curve of the spine. It helps to reduce the muscle strain and protect from the back pain.



LUMBAR SUPPORT

The lumbar support is mounted into the backrest and helps to reduce the muscle strain.



HEADREST

This additional part of the task chair helps to reduce tension in your neck muscles, provides support and comfort to the head and neck while in a reclined position.

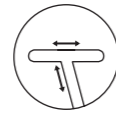

ADJUSTABLE ARMRESTS

Depending on the chair type armrests are adjustable in two, three or four directions (2D, 3D, 4D): height, width, the pad moves forwards and backwards or is rotatable. Height adjustment takes the strain off the neck muscles. Width adjustment and rotation allows the user to position the armrest in proper distance from the body and helps finding the most comfortable support angle.



WRITING TABLET

Rotatable. It allows users to put their notebooks, laptops or tablets upon.



STACKABLE

Chairs can be easily stacked one onto another. Therefore, they are perfect for offices with low storage space.



GLIDERS

Allow linking chairs in orderly rows.

narbutas

Connect with us:



narbutas.com



[linkedin.com/company/narbutas-international](https://www.linkedin.com/company/narbutas-international)



[facebook.com/NarbutasGroup](https://www.facebook.com/NarbutasGroup)



[instagram.com/narbutas_international/](https://www.instagram.com/narbutas_international/)



[pinterest.com/NARBUTASoffice](https://www.pinterest.com/NARBUTASoffice)